



The Wireless Connectivity Expert

48511 Warm Springs Blvd., Suite 206, Fremont CA 94539

Tel: (510) 490-8024 Fax: (510) 623-7268

Website: <http://www.actisys.com/> E-mail: irda-info@actisys.com

ACT-IR8200LA Chipset ***(ACT-IR8200L series+ ACT-IR220VACF)***

IrDA Compliant Protocol Processor

(IrLAP, IrLMP, TinyTP, etc.)

And IrDA SIR IrPHY Encoder/Decoder IC

**© Copyright 2001-2002 ACTiSYS Corporation,
All Rights Reserved**



Dec 04, 2002 Ver. 1.0

ACT-IR8200L series----- 2

ACT-IR220VACF -----23

ACT-IR8200L series

ACT-IR8200L

ACT-IR8200LM

ACT-IR8200LT

IrDA Compliant Protocol Processor

(IrLAP, IrLMP, TinyTP, etc.)

***© Copyright 2001-2002 ACTiSYS Corporation,
All Rights Reserved***

ACT-IR8200L series

Features	6
Overview	8
Embedded Firmware	9
Host Interface	10
Host Interface Signals	11
Jumpers and other optional hardware	13
Interfacing Serial EEPROM with ACT-IR8200L/LM/LT (Configuring by using EEPROM)	13
Host Baud Rate Setting (Configuring by using SEL0~7 pins , recommended)	14
Ignore DSR	15
Ignore CTS	15
EEPROM Function Disable	16
Evaluation board and Reference Design	17
How to implement :	18
How to test ACT-IR8200L/LM/LT functions and trouble shooting:	18
Part number	19
Packages:	20
PIN Description	21
Package Dimensions	22

ACTiSYS reserves the right to make changes without further notice to any products herein to improve reliability, function or design. ACTiSYS does not assume any liability arising out of the application or use of any product or circuit described herein.

Revision History		
Revision	Date	Comment
Rev. 0.9	07/03/2001	Draft Preliminary Design Specification for internal review.
Rev. 1.0	12/04/2002	Add implementation notes and trouble shooting

Features

Support IrDA standard including:

- IrLAP
- IrLMP
- TinyTP
- IrCOMM
- IrOBEX transport

Other standards:

- IrLPT : Secondary mode only.

IrDA baud rate supported:

- 9.6kbps
- 19.2kbps
- 38.4kbps
- 57.6kbps
- 115.2kbps

IrDA Primary/Secondary Mode supported:

- ACT-IR8200L : Secondary Mode only
- ACT-IR8200LM : Both Primary and Secondary Mode supported, and mode automatically switched upon IrDA protocol negotiation with the other device. When it enters Primary Mode , it runs IrCOMM 9-wire cooked protocol.
- ACT-IR8200LT : Secondary Mode only and using 2Kbytes buffer for both interface(IrDA and Host) by adding a external SRAM(32K x 8).

Host Interface:

- Full-duplex asynchronous serial (TXD, RXD)
(Or simplex TXD only and software flow control with RXD.)
- Hardware flow control (RTS, CTS)
- Optional line status for link control (DTR, DSR)
- Other optional inputs (RI, CD)

Host interface baud rate supported:

- 1.2kbps
- 2.4kbps
- 4.8kbps
- 9.6kbps
- 19.2kbps
- 38.4kbps
- 57.6kbps
- 115.2kbps

Overview

The ACT-IR8200L/LM/LT is a microprocessor with on-chip IrDA protocol stack. It is designed to integrate with a “host” system. This enables the host system with IrDA communication capabilities. The host system may be a serial printer, a modem, an industrial controller, a data collector, a medical instrument, or any other device, that may benefit from being IrDA enabled.

The interface between ACT-IR8200L/LM/LT and the host is via a traditional asynchronous serial data port.

IrDA Physical Layer (IrPHY) components are external to ACT-IR8200L/LM/LT. This includes an IrDA encoder-decoder chip and an IrDA transceiver module.

The IrPHY components and the ACT-IR8200L/LM/LT transport data in compliance with IrDA protocol. The host system has full control of communication sessions and data flow. It needs only to handle the Application of the data transported.

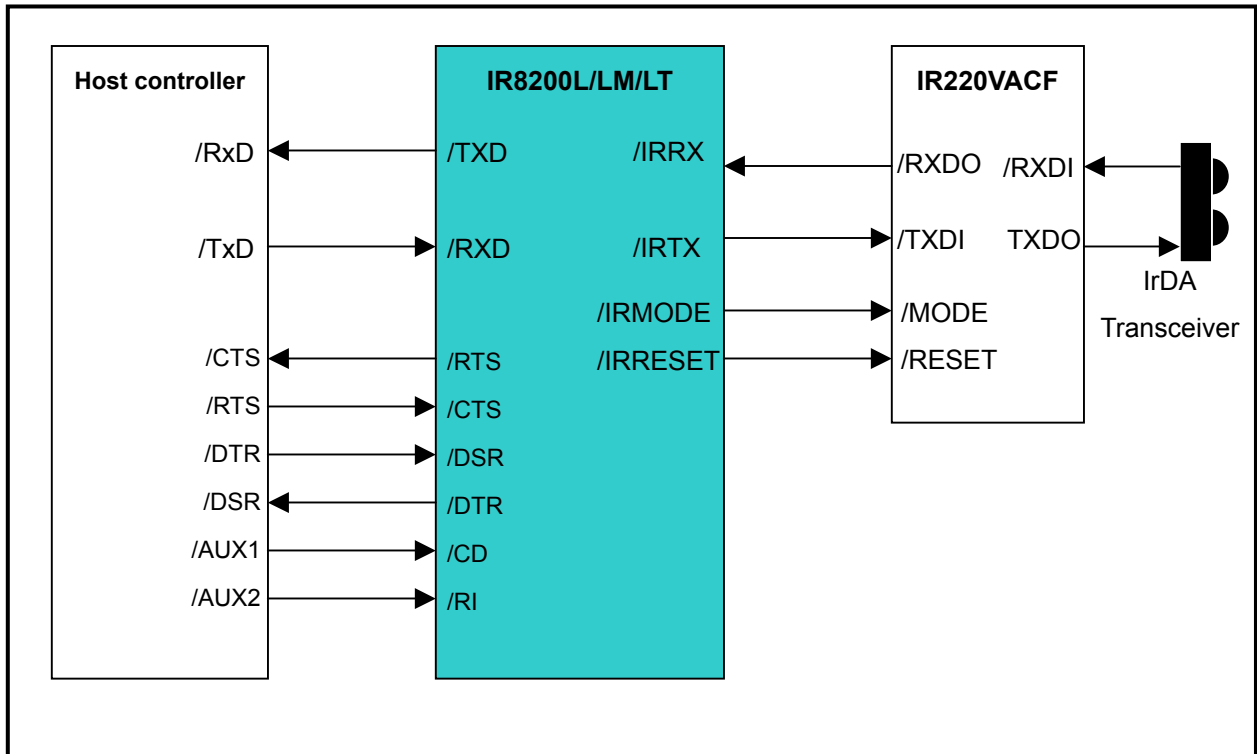

Embedded Firmware

The mandatory IrDA protocol layers, IrLAP (comply with TEST frame capability requirement) and IrLMP (including IAS) are handled by ACT-IR8200L/LM/LT, In addition, TinyTP, IrCOMM, IrLPT, IrOBEX transport are all included.

The incoming/outgoing IrDA user data payload are buffered and then transferred to/from the host. The baud rates of IrDA traffic and host interface are independent of each other. The flow controls of IrDA traffic and host interface are also independent of each other.

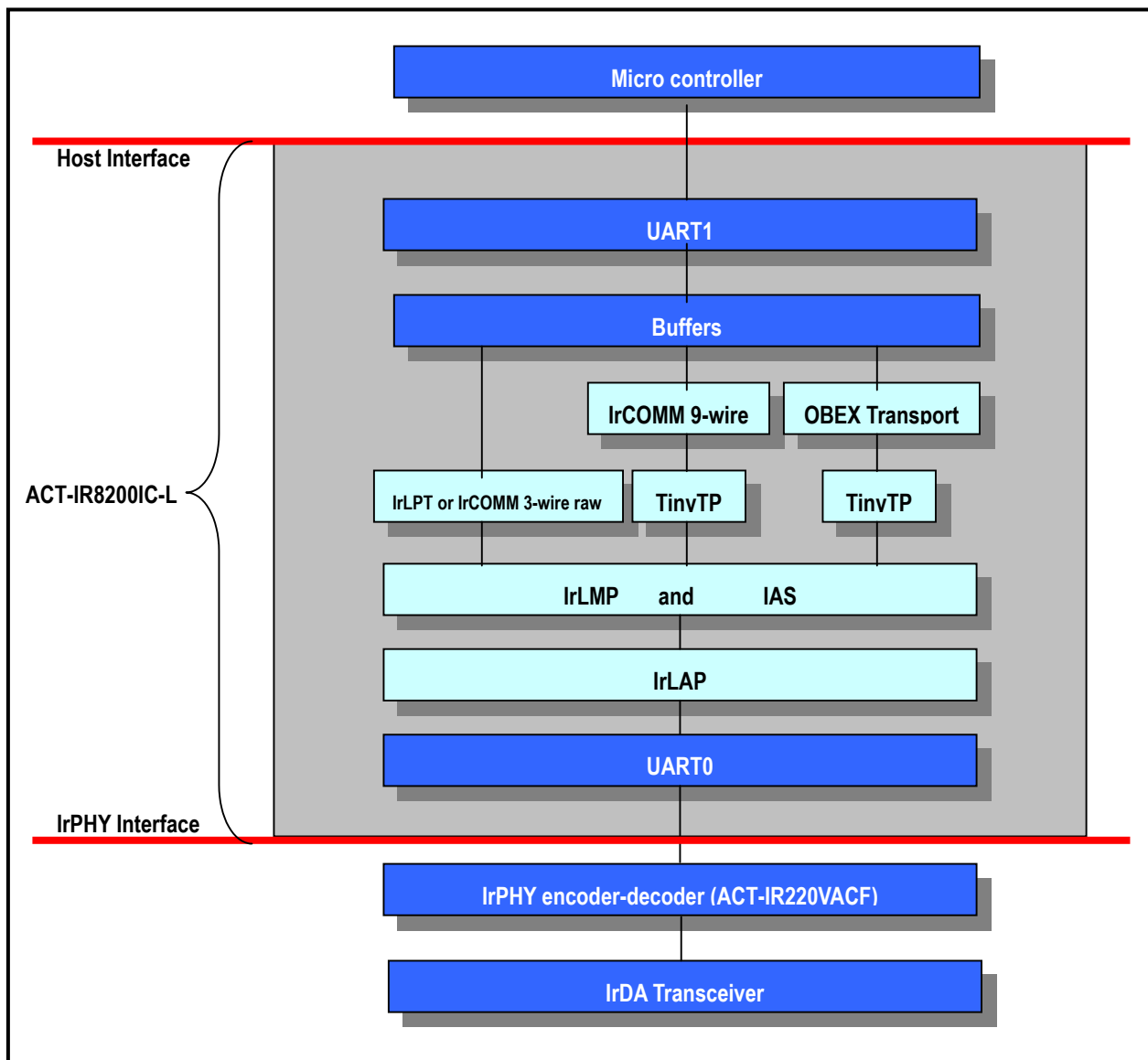

Host Interface

The host interface is a full-duplex asynchronous serial data interface. The data bytes are transmitted via /TXD and received via /RXD. Each data byte consists of one start bit (0), 8 data bits (LSB first, MSB last) and a stop bit (1).

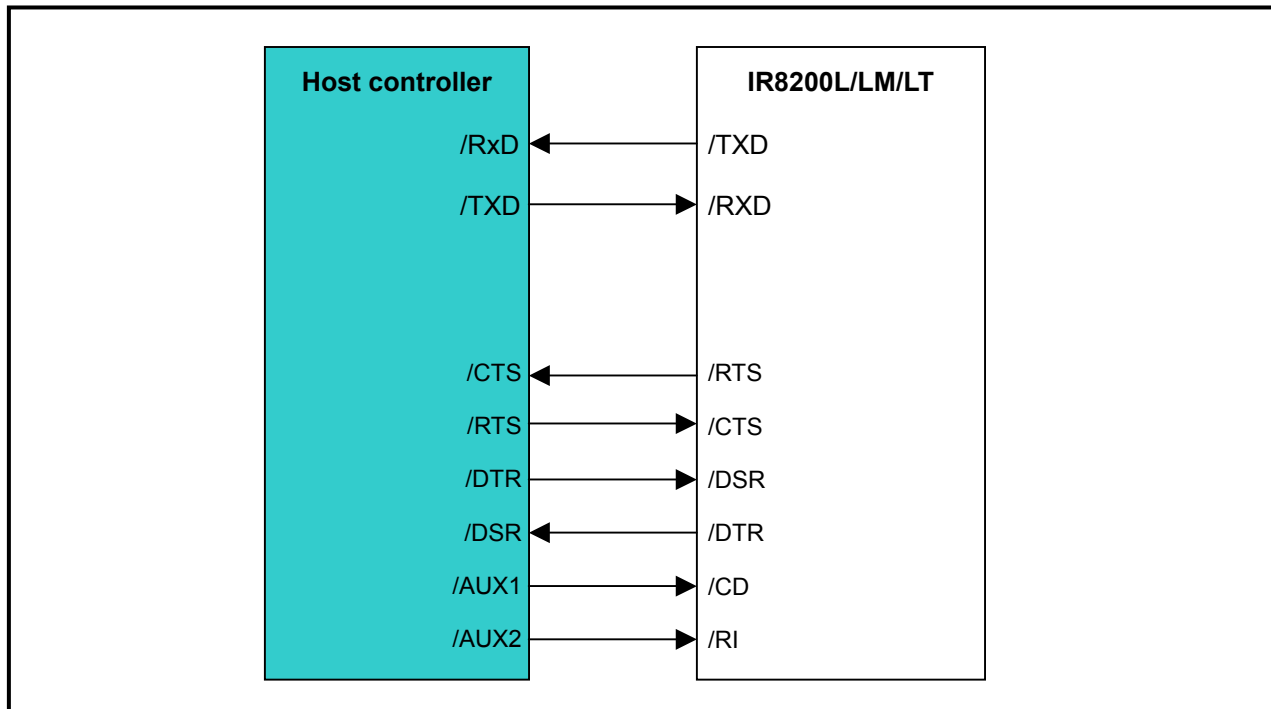
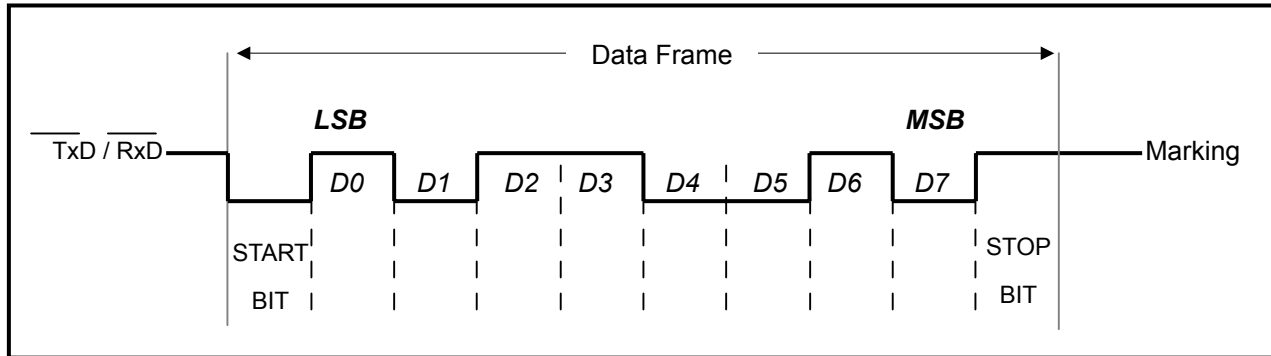

Host Interface Signals

ACT-IR8200L/LM/LT host interface consists of three output signals and five input signals. All these signals are active low. That is, they are at 0V when active and at VCC level when inactive. When an inverting RS232 level converter is used, the corresponding RS232 level signals are active high. That is, they are at +12V nominal when active and at -12V nominal when inactive.

1. /TXD: serial data output.
2. /RXD: serial data input.
3. /RTS: output. When hardware flow control is enabled, active /RTS means /RXD is ready to receive, inactive /RTS means /RXD is not ready.
4. /CTS: input. If hardware flow control is enabled, /CTS must be driven active to allow /TXD and inactive to forbid /TXD. If hardware flow control is disabled, /CTS is optional.
5. /DSR: input. If connection control is enabled, /DSR must be driven active to allow IrDA connection and inactive to forbid a new connection or terminate an existing connection. If connection control is disabled, /DSR is optional.
6. /DTR: output. If connection control is enabled, active /DTR means an IrDA connection is made, inactive /DTR means there is no connection.
7. /CD: input. Optional.
8. /RI: input. Optional.

IrPHY Interface

The IrPHY interface is a half-duplex asynchronous serial data interface; the data are exchanged of multiple wires (RXD, TXD) to single IR “wire” through the air.

So the IrPHY interface only working on transmitting or receiving mode, but not both at the same time.

The IrPHY interface baud rate supported: 9.6Kbps, 19.2kbps, 38.4kbps, 57.6kbps, 115.2kbps.

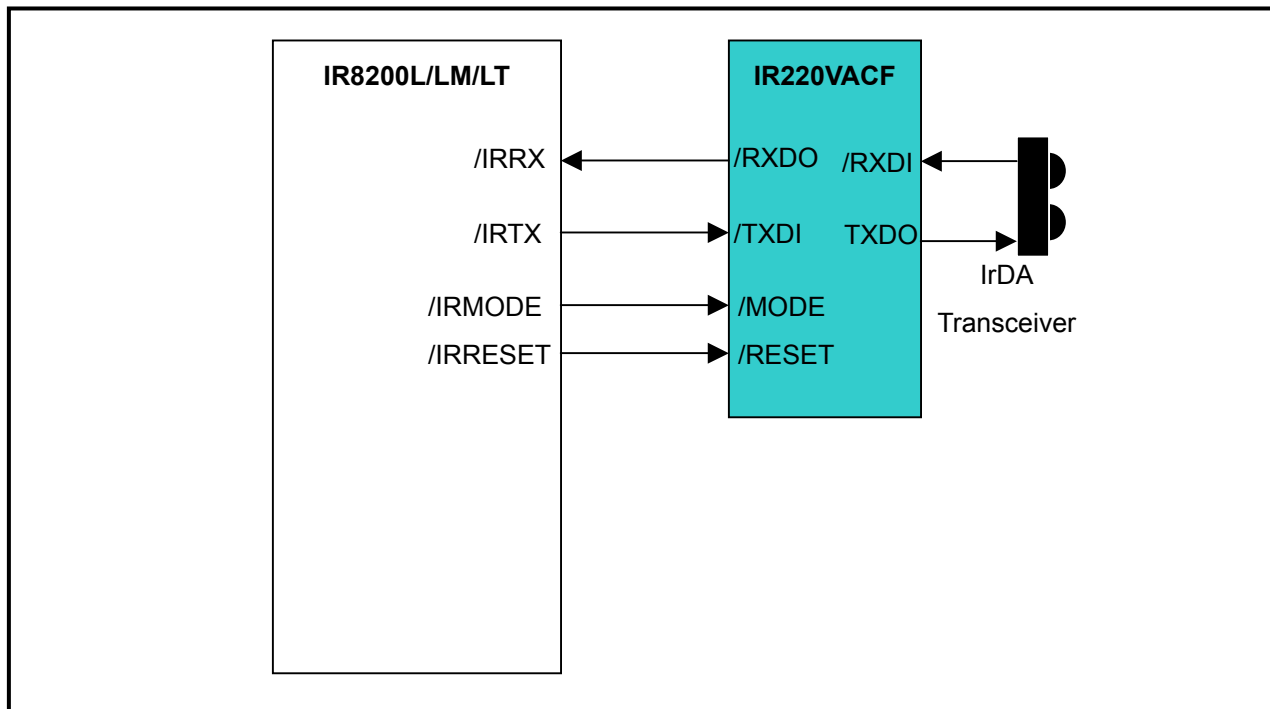

Jumpers and other optional hardware

ACT-IR8200L/LM/LT uses two methods to configure Host interface, include baud rate , enable/disable Hardware flow control. One is that use a EEPROM to store configuration, another is that pull high/low SEL0~7 pins to configure.

Interfacing Serial EEPROM with ACT-IR8200L/LM/LT (Configuring by using EEPROM)

There are some special functions if the external serial EEPROM installed.

The optional serial EEPROM allow users to set "Host Speed" and "Hardware Flow Control and Connection Control". The system initial sequence are shown below:

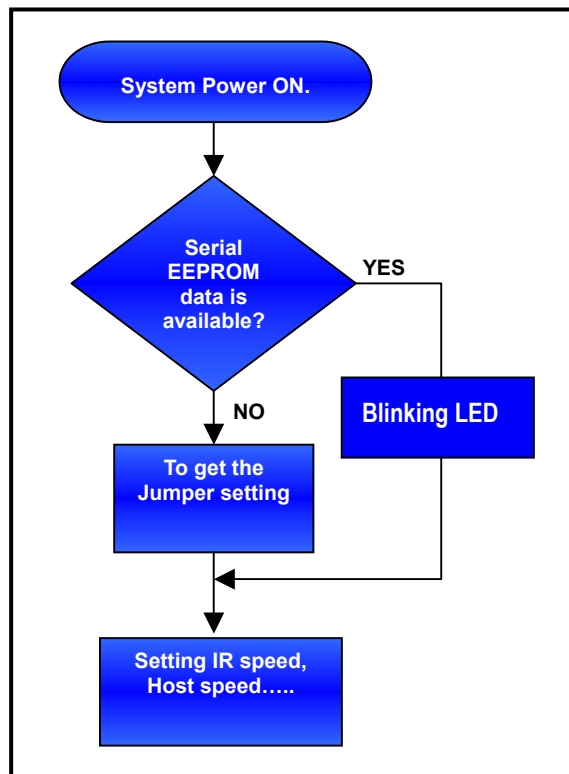

Note: The serial EEPROM setting can override jumper settings.

Host Baud Rate Setting (Configuring by using SEL0~7 pins , recommended)

Jumpers SEL0~SEL2 and serial EPROM settings are used to set the host interface /RXD and /TXD data rate. Note that this is independent of the IrDA connection data rate.

Data format is always 8 data bits, no parity, and 1 stop bit. Note that this is compatible with end-to-end data format using 7 data bits, parity, and 1 stop bit. That is, the application at both end of the IrDA link may generate and check parity if 7 data bit is used.

The Host Interface can operate on eight different baud rates from 1.2kbps to 115.2kbps.

Baud Rate	Jumpers		
	SEL2	SEL1	SEL0
1.2kbps	0	0	0
2.4kbps	0	0	1
4.8kbps	0	1	0
9.6kbps	0	1	1
19.2kbps	1	0	0
38.4kbps	1	0	1
57.6kbps	1	1	0
115.2kbps	1	1	1

0: means connect to GND.

1: means no connect.

Ignore DSR

SEL3 open (SEL3=1) means ignore the physical DSR input, pretend that DSR is on.

This logical DSR is always used for connection control.

The physical DTR is used for connection indication. SEL3 has no effect on DTR.

When SEL3 close (SEL3=0), DSR is used for connection control. Active DSR permits IrDA connection. Inactive DSR forbids new connection and terminates existing connection.

Ignore DSR	Jumper	Descriptions
	SEL3	
YES	1	Ignore DSR input.
NO	0	DSR is used for IR connection control.

0: means connect to GND.

1: means no connect.

Ignore CTS

SEL4 open (SEL4=1) means ignore the Physical CTS input, pretend that CTS is on.

This logical CTS is always used for TXD flow-control.

The physical RTS is used for RXD flow-control. SEL4 has no effect on RTS.

When SEL4 close (SEL4=0), CTS is used for flow control of TXD. Active CTS permits TXD. Inactive CTS forbids TXD.

Ignore CTS	Jumper	Descriptions
	SEL4	
YES	1	Ignore CTS input.
NO	0	CTS is used for RXD flow control.

0: means connect to GND.

1: means no connect.

EEPROM Function Disable

Jumper SEL7 is use to enable or disable EEPROM function.

If this function disable, IR8200L/LM/LT will use SEL0~SEL4 setting only.

If this function enable, IR8200L/LM/LT will use EEPROM setting and jumpers SEL0~SEL4 are ignored. **Note: SEL0~SEL4 must be setting when EEPROM function is disabled, otherwise the default will be 115.2kbps baud rate , enable RTS/CTS hardware flow control and disable DTR/DSR input.**

Function	Jumper	Descriptions
	SEL7	
Disable	0	Disable EEPROM function
Enable	1	Enable EEPROM function

0: means connect to GND.

1: means no connect.

Note:

1. SEL5 ~ SEL6 are reserved for future use.
2. Independent of the SEL3 or SEL4, software flow control is automatically used and DTR always active during IrLPT connection (this is used for printer host). In this case, if RXD received an X-OFF, TXD transmission is blocked. If RXD received an X-ON, TXD transmission may resume. In addition, hardware flow control may also be enabled.
3. For IrLPT, XON/XOFF flow control is always enabled. This is independent of SEL3 or SEL4.
4. In IrCOMM 9-wire connection IR8200IC-L/LM always response DCE line status if line state is changed or response Poll for Line Settings via IrLMP control channel.
Independent of the IR flow control, HOST data flow control and baud rate is not obey IrCOMM control parameters.

Evaluation board and Reference Design

It is recommended that you verify the compatibility with your host system by using our IrDA Protocol to RS232 Adapter, ACT-IR100S-L. This is a self-content unit, with ACT-IR8200L/LM/LT, IrPHY components, RS232-level converters and external AC power source, all built into a compact package. Also available for quick IrDA implementation is the internal PCB version. ACT-IR100S-L enables your host system to be IrDA (IrReady) certifiable immediately.

ACT-IR100S-L is designed to enable instant IrDA capability of your host via RS232 serial port; e.g. modem, serial printer, instrumentation, meter, data terminal and medical device. Once ACT-IR100S-L is proven to work well with your host system, and upon execution of mutual NDA and purchasing terms, we'll provide circuit diagrams to help speed up your implementation.

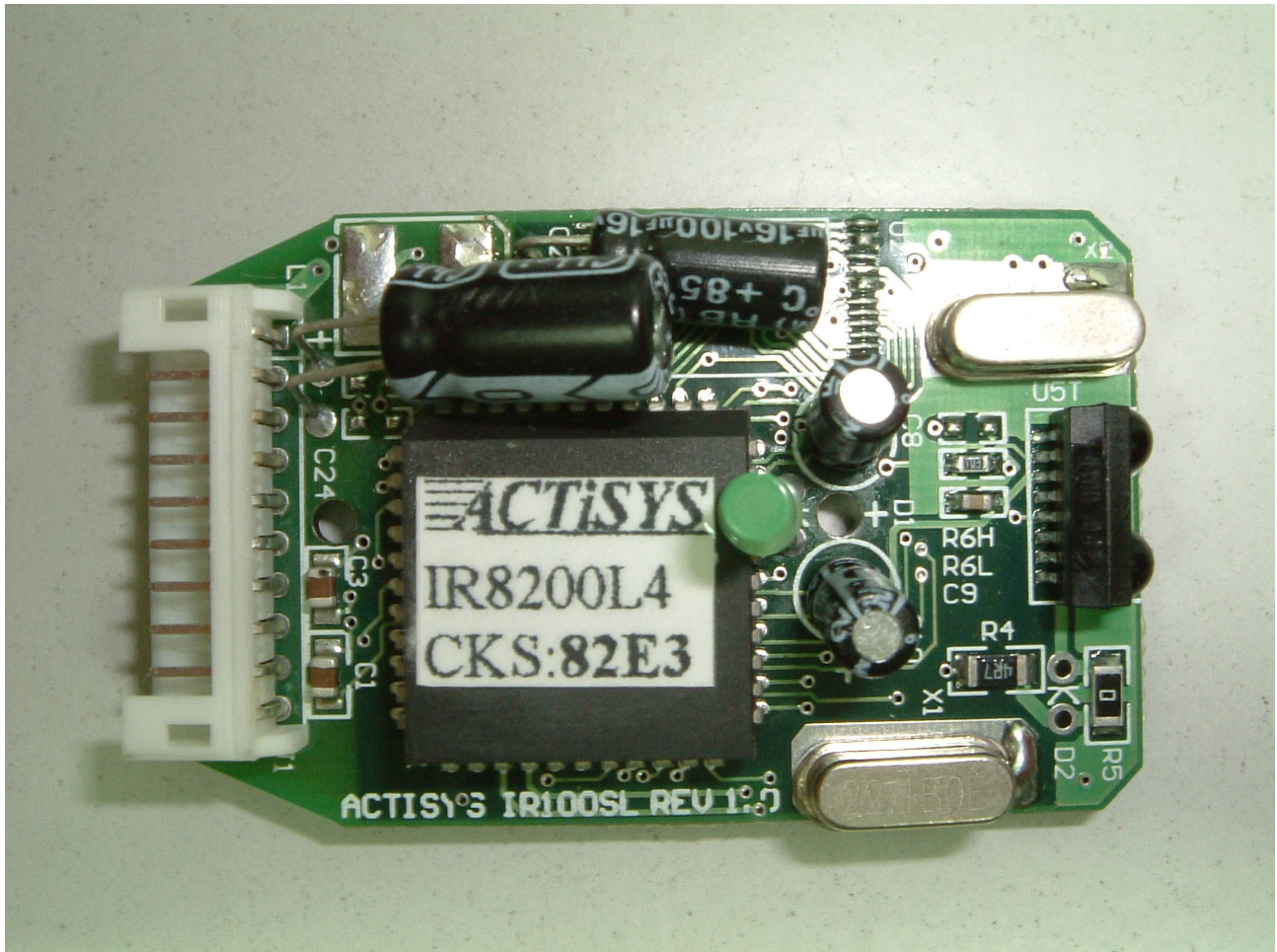

How to implement :

Before you implement this chip set into your board , you should notice following things:

- 1). Choose a SIR transeceiver module (like Vishay TDFU4100) , FIR is no need.
- 2). Place ACT-IR220VACF chip next to transeceiver module as close as possible. And keep chip away from high power consumption components.
- 3). When you disable EEPROM option , you should connect SEL7 to GND and configure SEL0~SEL4. If the baud rate of host side is fixed , then you don't need EEPROM to store that configuration. You just pull the SEL0~SEL4 to status what you want.
- 4). A0/D0~A7/D7 , ALE , /RD , /WR are not used unless you need external SRAM for bigger IrDA buffer(another firmware needs) , keep them open.
- 5). ACT-IR8200LM supports primary mode , you can pull /DSR input from high to low after power on to let ACT-IR8200LM enters primary mode. The difference between Primary mode and Secondary mode is that Primary sends Ir frame actively and Secondary waits Ir frame.
- 6). You can use some Infrared device on Windows 98/2000 to test it. If Windows 98/2000 shows that a Infrared device is detected , it means the infrared path of your board works. Then run Hyper terminal program in windows , and try to send something to Ir port , if your board can receive something from Windows , it means that host path works too. If can't , then check if CTS/RTS work.

How to test ACT-IR8200L/LM/LT functions and trouble shooting:

Measure signals on your PCB, using scope-probe and PDA-Ping SW or any Infrared device on Windows. Power up your board. At this point, you should have (Using QFP package for examples):

- 1). IR8200L/LM/LT-Pin 4 RESET Low
IR8200L/LM/LT-Pin 2 nCTS Low
IR8200L/LM/LT-Pin 1 nDSR Low
IR8200L/LM/LT-Pin 14/15 Xtal 22.1184MHz
IR220VACF-Pin3 /RESET High
IR220VACF-Pin4 /MODE High
IR220VACF-Pin 11 RXDI High
IR220VACF-Pin 2 RXDO High
IR220VACF-Pin 13 TXDO Low
IR220VACF-Pin 5 TXDI High
IR220VACF-Pin 9/10 XTAL 3.6864MHz

- 2). Hook up probes to IR220VACF-Pin 11 RXDI and IR220VACF-Pin 2 RXDO. Start PING.
You should see active low pulses of length 1.6 usec to 20 usec at IR220VACF-Pin 11.
You should see active low pulses of length 104 usec at IR220VACF-Pin 2.

- 3). Hook up probes to IR220VACF-Pin 13 TXDO and IR220VACF-Pin 5 TXDI. Start PING.
You should see active high pulse of length 1.6 usec at IR220VACF-Pin 13.
You should see active low pulses of length 104 usec at IR220VACF-Pin 5.

Part number

ACT-IR8200aabV-c

aa : L , LM , LT

b : 3 (3V) , 5 (5V)

c : P(PLCC) , Q (QFP)

For example :

ACT-IR8200L3V-P : IR8200L , operating voltage : 3.3V , Package : PLCC 44 pin.

Packages:

- PLCC 44 pin
- QFP 44 pin

DC electrical characteristics:

- Operating voltage: 2.7 ~ 5.5 VDC
- Operating current: Active < 50mA (No load)

Operating temperature:

- 0°C ~ +70°C
- -40°C ~ +85°C (Industrial Temperature version).

Storage temperature:

- -55°C ~ +150°C

44-Pin PLCC

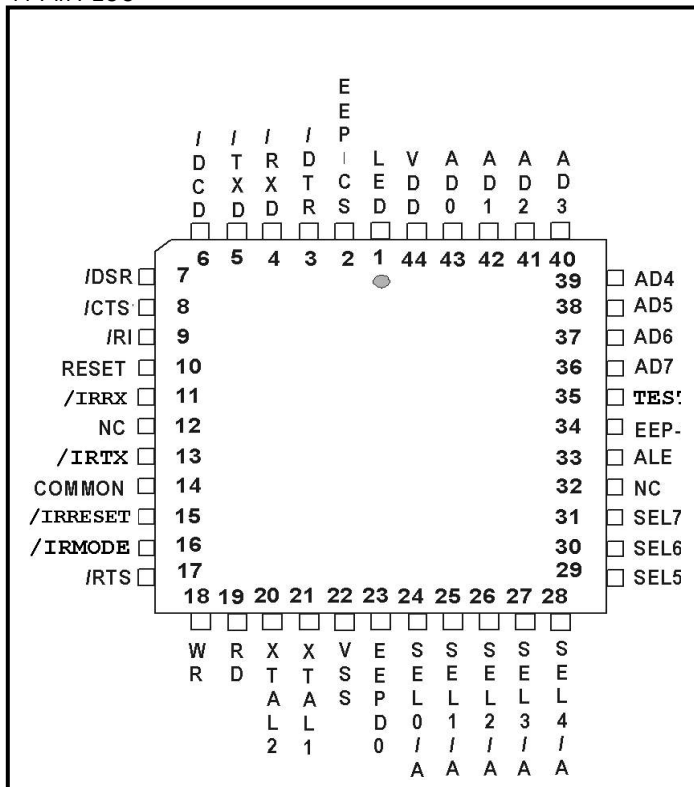

44-Pin QFP

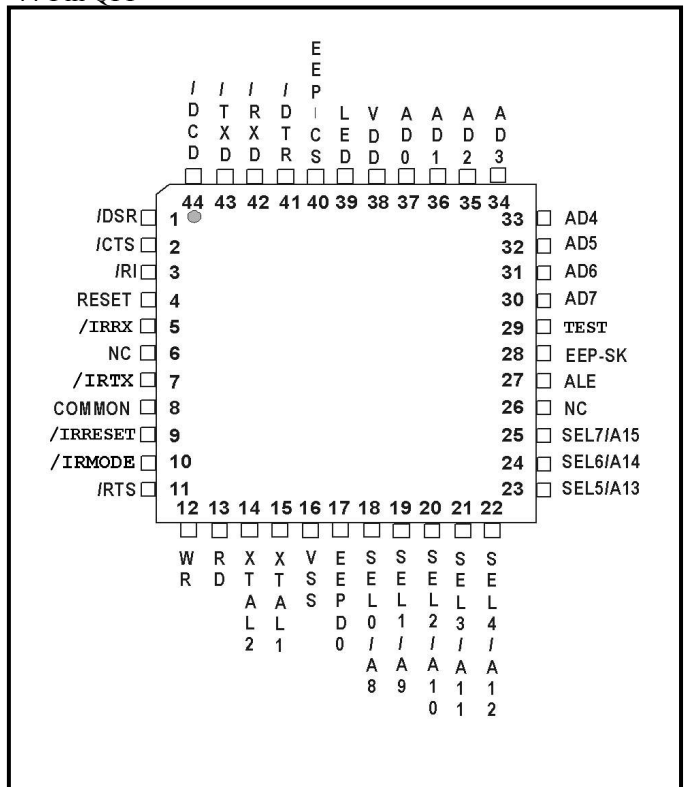

PIN Description

Group	Symbol	Pin No. (PLCC)	Pin No. (QFP)	I/O Type	Descriptions
1	/DTR	3	41	O	Data terminal Ready
	/RXD	4	42	I	Receiver Data from Host
	/TXD	5	43	O	Transmitter Data to Host
	/CD	6	44	I	Data Carrier Detect
	/DSR	7	1	I	Data Set Ready
	/CTS	8	2	I	Clear To Send
	/RI	9	3	I	Ring Indicator
	/RTS	17	11	O	Request To Send
2	EEP-SK	34	28	I/O	EEPROM clock
	EEP-DO	23	17	I/O	EEPROM data
	EEP-CS	2	40	O	EEPROM Chip Select
	A7 ~ A0	36 ~ 43	30 ~ 37	I/O	External RAM address bus
	D7 ~ D0	36 ~ 43	30 ~ 37	I/O	External RAM data bus
	A8 ~ A15	24 ~ 31	18 ~ 25	O	External RAM address bus
	ALE	33	27	O	Address latch enable
3	SEL0	24	18	I	Host baud rate selection
	SEL1	25	19		
	SEL2	26	20		
	SEL3	27	21		
	SEL4	28	22	I	Ignore DSR
	SEL5, SEL6	29, 30	23, 24		Reserved for future use
	SEL7	31	25	I	Disable EEPROM
	COMMON	14	8	O	Common return for SEL0 ~ SEL6
4	/IRMODE	16	10	O	ACT-IR220VACF mode selection
	/IRRESET	15	9	O	ACT-IR220VACF reset signal
	/IRTX	13	7	O	Data out to ACT-IR220VACF
	/IRRX	11	5	I	Data in from ACT-IR220VACF
5	LED	1	39	O	System status indicator
	VDD	44	38	-	Supply voltage for operation
	VSS	22	16	-	Ground potential
	XTAL1	21	15	I	Crystal oscillator input
	XTAL2	20	14	O	Crystal oscillator output
	RESET	10	4	I	Reset the device
	TEST	35	29	I	Choose Int/Ext ROM. Pull it High

TYPE I: Input, O: Output

GROUP 1: Host Interface, 2: Optional hardware, 3: Jumper setting, 4: IrPHY Interface, 5: Others

Package Dimensions

44-PIN PLCC

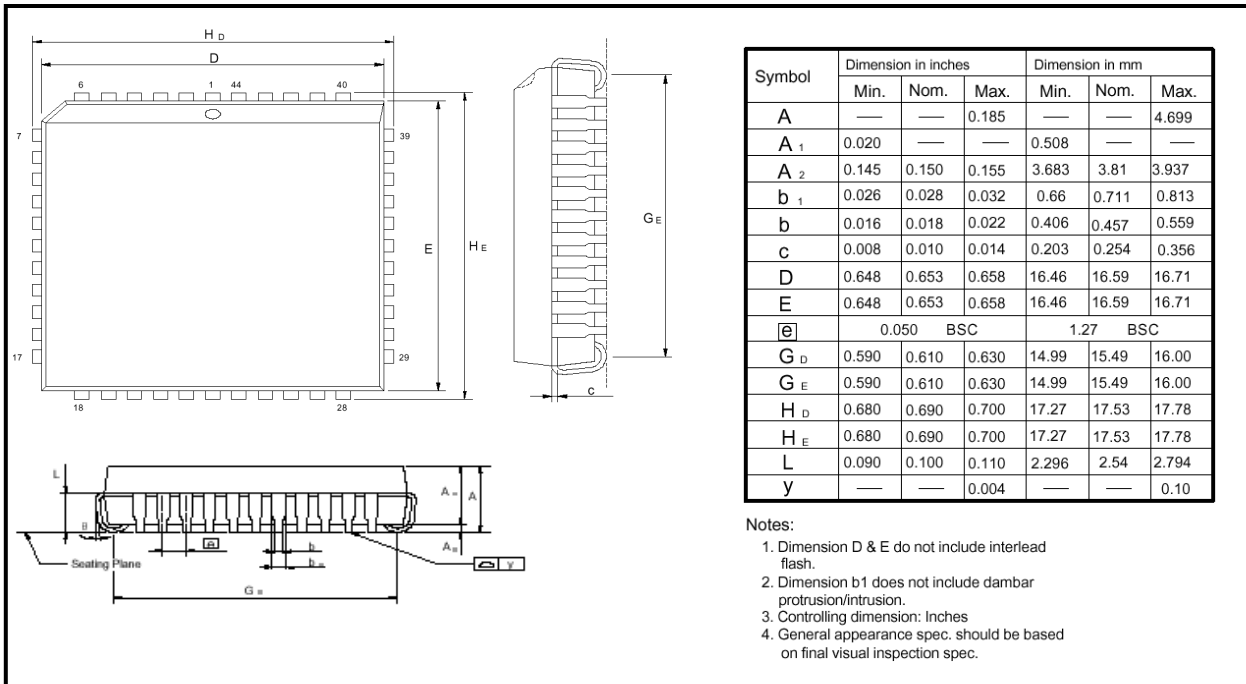

44-PIN QFP

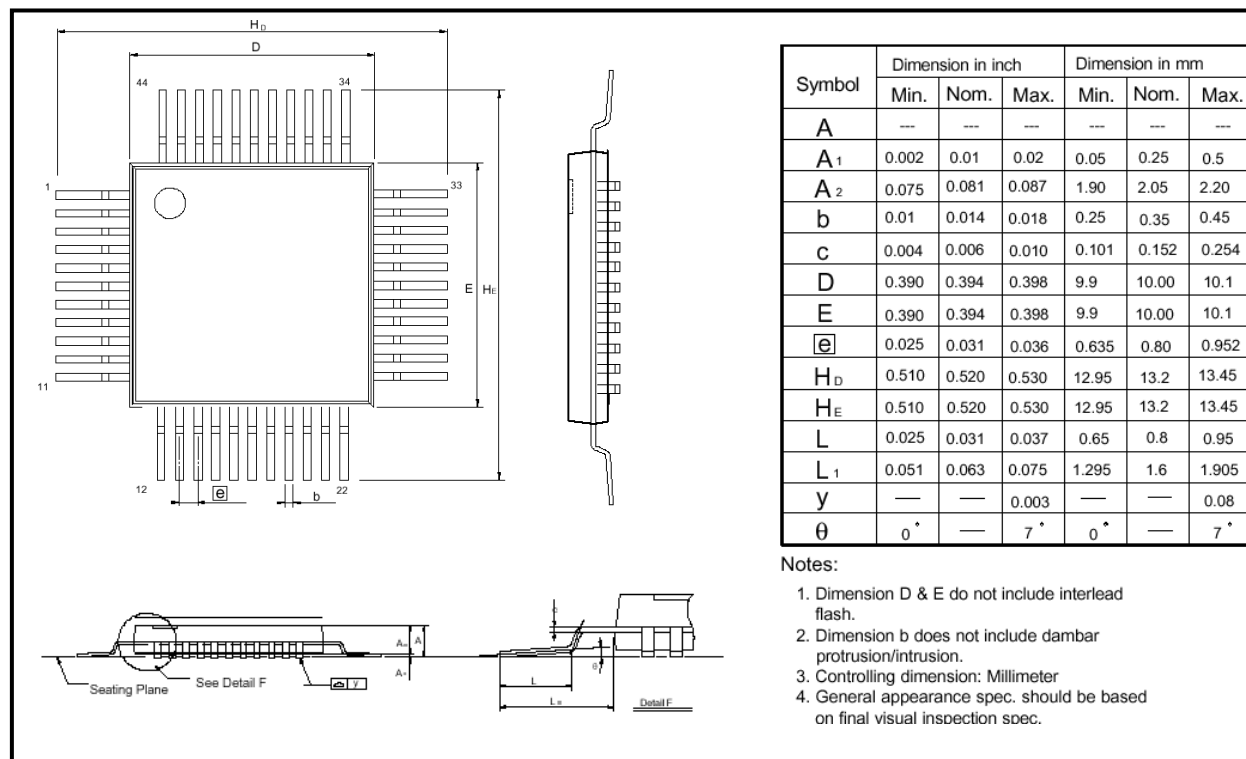

ACT-IR220VACF

IRDA SIR Encoder/Decoder IC Specification

*© Copyright 2002 ACTiSYS Corporation,
All Rights Reserved*

Nov. 12, 2002 Rev.1.1.1

ACT-IR220VACF

Description	26
Features	26
Block Diagram	26
Pin Assignment and Description	27
Control Function	28
Application Circuit	29
Electrical Characteristics	30
Package Dimensions	32
Warranty Information	33
Contact Information	34

Revision History		
Revision	Date	Comment
Rev. 1.0	06/28/2001	Draft Preliminary Design Specification for internal review.
Rev. 1.1	09/13/2002	Add Electrical Characteristics
Rev. 1.1.1	11/12/2002	Editorial Corrections

Description

The ACT-IR220VACF is a half-duplex infrared communication processor that encodes RS232 compatible electrical signal pulses to IrDA compatible electrical pulses, and decodes IrDA compatible electrical pulses to RS232 (needs level converter) pulses, ACT-IR220VACF supports data baud rate from 9.6Kbps to 115.2Kbps.

The ACT-IR220VACF uses crystal clock 3.6864 MHz for its pulse stretching and shortening. The IrPHY specification allows two kinds of modulations: 3/16 of a bit duration pulse, or minimum pulse duration of 1.63 μ s, we are using minimum pulse duration of 1.63 μ s to modulate bit data.

Features

- IrPHY encoding/decoding and interfaces directly to IrDA transceivers.
- 3.3 V to 5.5 V operating voltage.
- Using minimum pulse duration of 1.63 μ s to modulation bit data.
- Programmable baud clock generator (9600bps to 115.2 Kbps) 5 baud rates.
- Low operating current
- SOP14 – package

Block Diagram

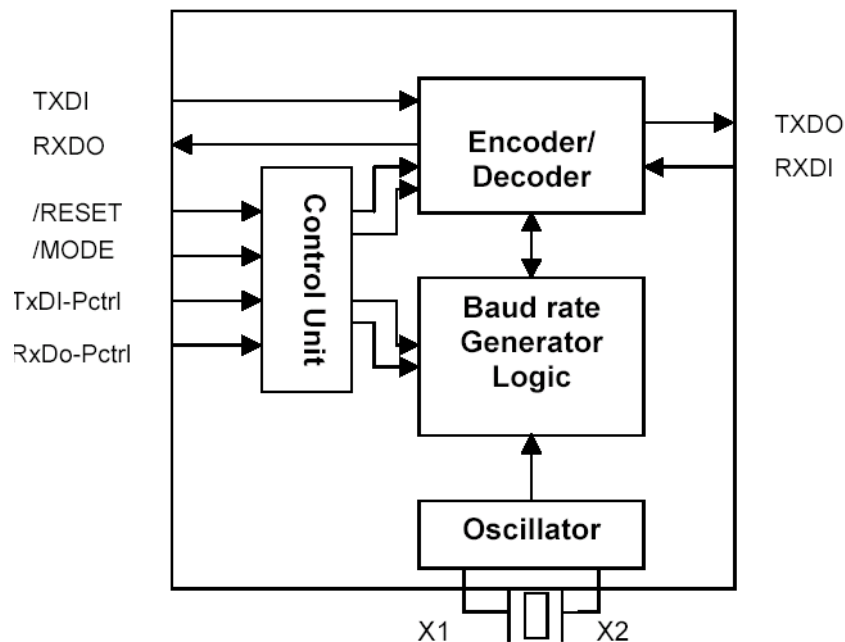











Figure 1. Block diagram

Pin Assignment and Description

Symbol	Pin No.	I/O Type	Descriptions
NC	1 & 8		No connect.
RXDO	2	Output	Receiving Data Output. It is active when infrared signals come from RXDI pin. It depends on RXDO-PCTRL pin to control active level. It can be connected to the UART interface of micro controller.
RESET	3	Input	Reset chip signal. Low active. Pulling this pin Low for 200ns, it will reset the baud rate to 9.6kbps.
MODE	4	Input	Changing mode signal. Low active. Pulling this pin Low for 200ns, it will change the chip baud rate to next speed. There are 5 baud rates supported by IR220VACF.
TXDI	5	Input	Transmitting Data Input. The data that comes from TXDI pin will be translated to infrared signals and sent to TXDO pin. It depends on TXDI-PCTRL pin to control active level. It can be connected to UART interface of micro controller.
TXDI-PCTRL	6	Input	When TXDI-PCTRL is "LOW", the TXDI will be HIGH active. When TXDI-PCTRL is "HIGH", TXDI will be change to LOW active.
GND	7	Power	Ground.
XTAL	9 & 10		Crystal input clock, 3.6864 MHz nominal. Input for external clock.
RXDI	11	Input	Infrared signals input. This pin is connected to the Infrared signals that comes from receiving pin of transceiver module
RXDO-PCTRL	12	Input	When RXDO-PCTRL is "LOW", the RXDO will be HIGH active, when RXDO-PCTRL is "HIGH", RXDO will be change to LOW active.
TXDO	13	Output	Infrared signals output. This pin is connected and sends infrared signals to transmitting pin of transceiver module.
VCC	14		Power supply.

Control Function

The following table shows how IR220VACF changes its baud rate. When IR220VACF is powered, it stays at 9.6Kbps. By pulling the /MODE signal low for more than 200ns, you can change the baud rate. Pulls one low pulse, change to next baud rate. Another low pulse, will change to another baud rate. There are totally 5 baud rate speeds that can be selected.

Symbol	RESET	MODE	Descriptions
9.6Kbps		Don't Care	Basic backward Compatible modes
19.2Kbps	Hi	1 x 	
57.6Kbps	Hi	2 x 	
115.2Kbps	Hi	3 x 	
38.4Kbps	Hi	4 x 	
No use	Hi	5 x 	
No use	Hi	6 x 	
No use	Hi	7 x 	
ASK mode	Hi	8 x 	

Application Circuit

Figure 2. ACT-IR220VACF application circuit

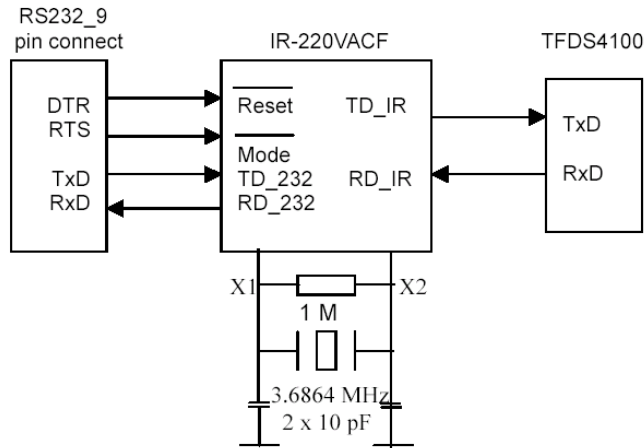

Figure 3. Application Block Diagram

Table 1. Recommended Application Circuit Components

Component	Recommended Value	Component	Recommended Value
C9	100 nF	R5	0 R
C10	10 μ F	R6	10K R
C11	10 pF	R7	10K R
C12	10 pF	R8	1M R
C13	100 nF	R9	22 R
R3	22 R	D2	Ir LED
R4	2R2	X2	3.686400 MHz Crystal

Electrical Characteristics

Absolute Maximum Ratings

Symbol	Parameter	Rating	Units
Vcc	Power Supply	-0.3 to 6.0	V
VIN	Input Voltage	-0.3 to Vcc+0.3	V
VOUT	Output Voltage	-0.3 to Vcc+0.3	V
TSTG	Storage Temperature	-40 to 125	$^{\circ}$ C

Recommended Operation Conditions

Symbol	Parameter	Min	TYP	Max	Units
Vcc (5V)	Power Supply (5V)	4.75	5.0	5.25	V
VIN	Input Voltage	0		Vcc	V
TOPR	Storage Temperature	0		70	$^{\circ}$ C

General DC Characteristics

Symbol	Parameter	Conditions	Min	TYP	Max	Units
IIL	Input low current	No pull-up or pull-down	-1		1	μ A
IIH	Input high current	No pull-up or pull-down	-1		1	μ A
IOZ	Tri-state leakage current		-10		10	μ A
CIN	Input capacitance			3		pF
COUT	Output capacitance			3 to 6		pF
CBID	Bi-directional buffer capacitance			3 to 6		pF

DC Electrical Characteristics for 5 volts operation

(Under Recommended Operation Conditions and Vcc=4.75v ~ 5.25v, Tj=0°C to +70°C)

Symbol	Parameter	Conditions	Min	TYP	Max	Units
VIL	Input Low Voltage	TTL			0.8	V
VIL	Input Low Voltage	CMOS			0.3*Vcc	V
VIL	Schmitt input Low Voltage	TTL		1.12		V
VIL	Schmitt input Low Voltage	CMOS		1.76		V
VIH	Input High Voltage	TTL	2.2			V
VIH	Input High Voltage	CMOS	0.7*Vcc			V
VIH	Schmitt input High Voltage	TTL		2.00		V
VIH	Schmitt input High Voltage	CMOS		3.20		V
VOL	Output low voltage	IOL=4,8,12,16,24 mA			0.4	V
VOH	Output high voltage	VOH=4,8,12,16,24 mA	3.5			V
PG	Gate Power	Per Gate/MHz		4.7		μ W
RI	Input Pull-up/down resistance	Vil=0v or Vih=Vcc		50		K Ω

Package Dimensions

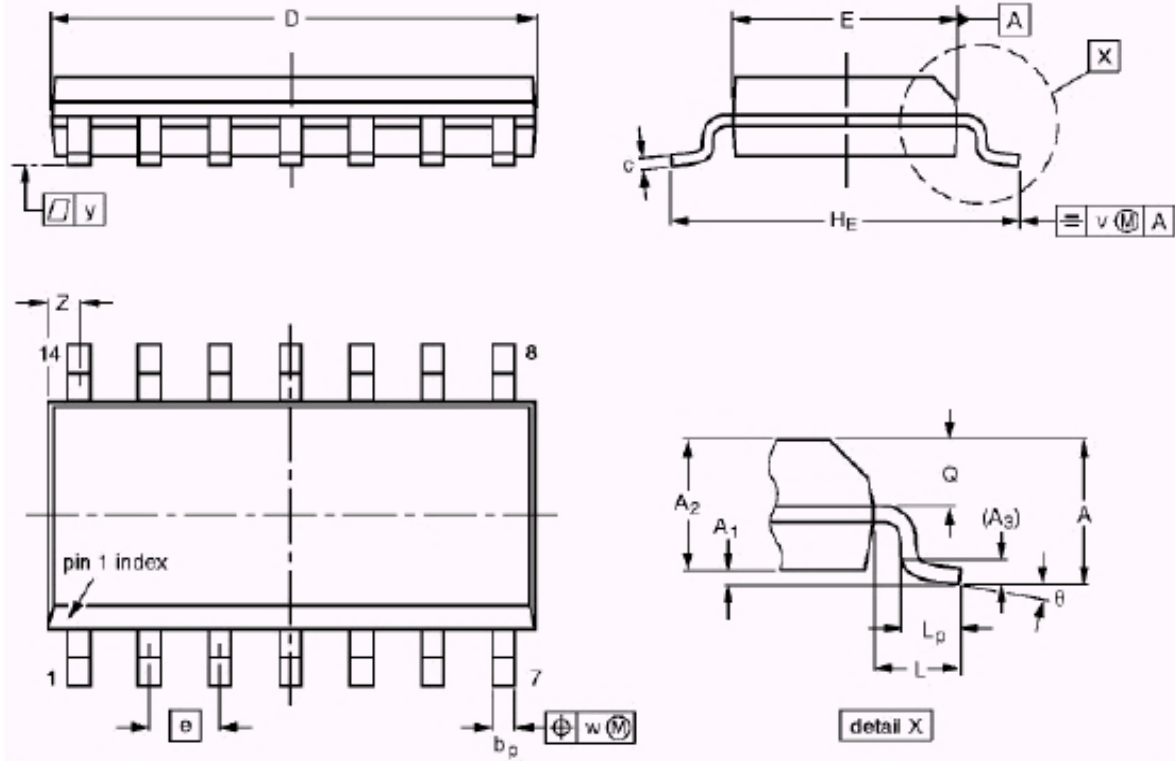

DIMENSIONS (Inch dimensions are derived from the original mm dimensions)

UNIT	A max.	A ₁	A ₂	A ₃	b _p	c	D ⁽¹⁾	E ⁽¹⁾	e	H _E	L	L _p	Q	v	w	y	Z ⁽¹⁾	θ
mm	1.75	0.25 0.10	1.45 1.25	0.25	0.49 0.36	0.25 0.19	8.75 8.55	4.0 3.8	1.27	6.2 5.8	1.05	1.0 0.4	0.7 0.6	0.25	0.25	0.1	0.7 0.3	8° 0°
inches	0.069	0.0098 0.0039	0.057 0.049	0.01	0.019 0.014	0.0098 0.0075	0.35 0.34	0.16 0.15	0.050	0.24 0.23	0.041	0.039 0.016	0.028 0.024	0.01	0.01	0.004	0.028 0.012	

Note

1. Plastic or metal protrusions of 0.15 mm maximum per side are not included.

Warranty Information

ACTiSYS Corporation warrants to the first consumer purchaser, for a period of 1 year from the date of purchase, that this wireless interface (The Product) will be free from defective workmanship and materials, and agrees that it will, at its option, either repair the defect or replace the defective Product or part thereof at no charge to the purchaser for parts or for labor.

This warranty does not apply to any appearance items of the Product, any consumable items such as paper, ink, ribbon, or batteries supplied with the Product, or to any equipment or any hardware, software, firmware, or peripheral other than the Product. This warranty does not apply to any Product the exterior of which has been damaged or defected, which has been subjected to misuse, abnormal service or handling, or which has been altered or modified in design, construction or interfacing. Tampering With Label Voids Warranty.

In order to enforce the rights under this limited warranty, the purchaser should mail, ship, or carry the Product, together with proof of purchase, to ACTiSYS.

The limited warranty described above is in addition to whatever implied warranties may be granted to purchasers by law. To the extent permitted by applicable law, ALL IMPLIED WARRANTIES INCLUDING THE WARRANTIES OF MERCHANTABILITY AND FITNESS FOR USE ARE LIMITED TO A PERIOD OF 1 YEAR FROM THE DATE OF PURCHASE. Some states do not allow limitations on how long an implied warranty lasts, so the above limitation may not apply to you.

Neither the sales personnel of the seller nor any other person is authorized to make any warranties other than those described above, or to extend the duration of any warranties beyond the time period described above on behalf of ACTiSYS Corporation.

The warranties described above shall be the sole and exclusive remedy available to the purchaser. Correction of defects, in the manner and for the period of time described above, shall constitute full satisfaction of all claims, whether based on contract, negligence, strict liability or otherwise. In no event shall ACTiSYS Corporation be liable or in any way responsible, for any damages or defects in the Product which were caused by repairs or attempted repairs performed by anyone other than ACTiSYS technician. Nor shall ACTiSYS Corporation be liable or in any way responsible for any incidental or consequential economic or property damage. Some states do not allow the exclusion of incidental or consequential damages, so the above exclusion may not apply to you.

Contact Information

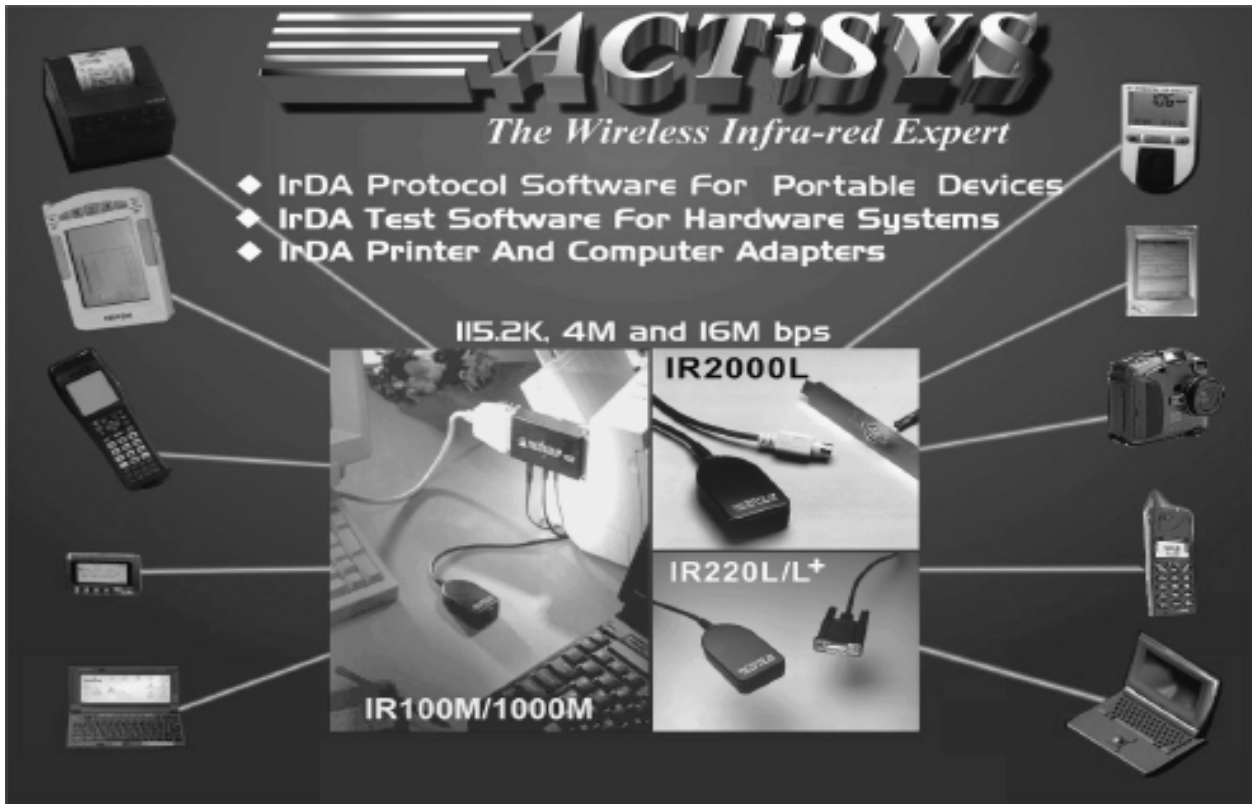

ACTiSYS Corporation.

48511 Warm Springs Blvd, Suite 206

Fremont, CA 94539, USA

TEL: (510) 490-8024, FAX: (510) 623-7268

E-Mail: irda-support@actisys.com

Web: www.actisys.com