



48511 Warm Springs Blvd., Suite 206, Fremont CA 94539

Tel: (510) 490-8024 Fax: (510) 623-7268

Website: <http://www.actisys.com/> E-mail: irda-info@actisys.com



ACT-IR320L

Long distance Infrared Adapter

User's Manual

© Copyright 2000-2002 ACTiSYS Corporation,
All Rights Reserved

Apr. 18, 2003 Ver. 0.1

| Revision History | | |
|-------------------------|-------------|---|
| Revision | Date | Comment |
| Rev. 0.1 | 02/28/2002 | Draft Preliminary Design Specification for internal review. |
| | | |
| | | |
| | | |

TABLE OF CONTENTS

1. Overview 3

2. Features 4

3. Applicable description 4

4. DTE-DB9M Connector description 5

5. Characteristics and Specification 6

1. Overview

The ACT-IR320L is a long distance infrared adapter that enables the host system with long distance infrared communication capabilities. The host system may be an industrial controller, a data collector, a medical instrument, or any other device. The interface between ACT-IR320L and the host is via a traditional asynchronous serial data port (RS232C). Figure 1.1 shows the system block diagram.

Figure 1.1 System Block Diagram

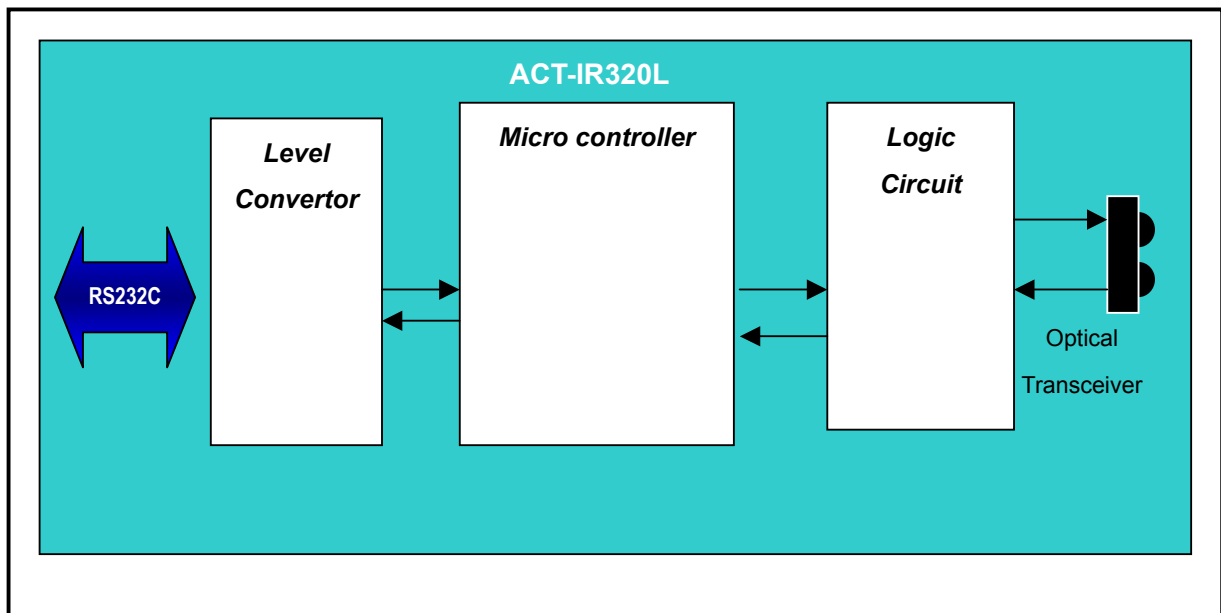

2. Features

- Long distance transmitting/receiving adapter by using 455KHz ASK-IR technology.
- Supports max. 15 meters transmitting/receiving distance.
- 9.6kbps, 19.2kbps and 38.4kbps RS232 baud rate supported.
- Instantly convert RS232 Port to IR, without special IrDA protocol SW and use existing application SW.
- True cable-to-IR replacement using ASK-IR technology.
- No SW Modification Required: Single IR Speed using IR320L, used as a pair.
- No buffer in circuit, no delay causes.

3. Applicable description

ACT-IR320L uses 455KHz ASK-IR technology to support long distance transmitting/receiving, ASK-IR is a technology that base on sub-carrier and it is not compatible to IrDA. Therefore, it should be used as a pair when using IR320L.

Once ACT-IR320L is connected to serial port of host device, it enters ready mode, the LED is lighting. There are two ways can make IR320L to enter active mode. One is the host device sends some data to it by passing RxD pin, another is that IR320L receives ASK sub-carrier from outside and passes those data to TxD pin. When IR320L is in active mode, the LED is flashing. ACT-IR320L detects RxD pin's level and turn the ASK sub-carrier on and off when it is sending data, thus it is no need to care about baud rate setting, but limited by the frequency of ASK modulation, the baud rate supported up to 38.4Kbps.

Generally, there is two ways to connect to a serial port. One is 3-wires(Flow control free), another is 9-wires(Flow control enables). Based on the ACT-IR320L is no buffer in circuit, it is a 3-wires operating dongle, it doesn't has to enable flow control mechanism. It means that it doesn't detect the DSR and CTS pins from host device and always pull DTR and RTS pins to high. Application program should take care about flow control itself.

The radiant intensity of ACT-IR320L relates to angle between two dongles that face to face, the Angle of half intensity is +/- 10°. It will get more effective performance by adjusting angle.

4. DTE-DB9M Connector description

ACT-IR320L is a DTE adapter, like serial port on PC, it can connect to any DCE device directly. If you want to connect this adapter to Notebook or Desktop computer, the DB9F-to-DB9F converter is needed. The converter plays like a null-modem, redirects serial port signals from DTE to another DTE.

| Pin No. | Name | Descriptions | I/O |
|---------|------|---------------------|-----|
| 1 | CD | Data Carrier Detect | I |
| 2 | RXD | Receiver Data | I |
| 3 | TXD | Transmitter Data | O |
| 4 | DTR | Data Terminal Ready | O |
| 5 | GND | Signal Ground | GND |
| 6 | DSR | Data Set Ready | I |
| 7 | RTS | Request to Send | O |
| 8 | CTS | Clear to Send | I |
| 9 | RI | Ring Indicator | I |

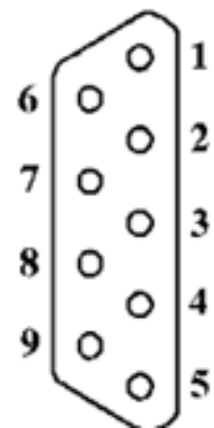

Front View

5. Characteristics and Specification

| Parameter | MIN. | TYPICAL | MAX. | Units |
|--|------|---------|-------|-------|
| DC supply voltage | 5.0 | 7.5 | 12 | V |
| Supply voltage, VSS | | 0 | | V |
| Operating free-air temperature range, TA | 0 | | 40 | °C |
| DC current (Ready mode) | | 2 | | mA |
| DC current (Active mode) | | 200 | 300 | mA |
| | | | | |
| RS232 signal threshold level | +/-3 | +/-12 | +/-25 | V |
| | | | | |