



48511 Warm Springs Blvd., Suite 206, Fremont, CA 94539, USA

Tel: +1-510-490-8024

Fax: +1-510-623-7268

Web: <http://www.actisys.com>

E-mail: irda-info@actisys.com

ACT-IR8200D
OBEX Server
IrDA Compliant Protocol Processor
Design Specification



January 9, 2007

Version 1.1

© Copyright 2004~2007 ACTiSYS Corporation
All Rights Reserved

TABLE OF CONTENTS

REVISION HISTORY	3
1. FEATURES	4
2. OVERVIEW	6
3. HOW TO CONFIGURE ACT-IR8200D?	7
3.1. Wiring Note.....	7
3.2. The First Tab: Host Settings	7
3.3. Flow Control Note	8
3.4. The Second Tab: Discovery Timing Settings.....	9
3.5. The Third Tab: Primary Protocol Settings	10
3.6. Save Configuration	10
4. APPLICATION CIRCUIT	11
5. PACKAGE DIMENSIONS	12
6. WARRANTY INFORMATION	14
7. CONTACT INFORMATION.....	15

REVISION HISTORY

Revision History		
Revision	Date	Comment
1.0	11/27/2006	Initial released
1.1	1/9/2007	Extracted technical sections

ACTiSYS reserves the right to make changes without further notice to any products herein to improve reliability, function or design. ACTiSYS does not assume any liability arising out of the application or use of any product or circuit described herei

1. FEATURES

- Complete IrDA Protocol stack in a single chip.
- No driver is needed.
- Includes IrPHY encoding/decoding and interfaces directly to infrared transceivers for data rate up to 115.2 kbps. Only an external infrared transceiver is needed to complete an IrDA compliant infrared communication subsystem.
- Supports mandatory IrDA layer: IrPHY, IrLAP, IrLMP and IAS.
- Supports upper layers TinyTP, IrCOMM, IrLPT, and OBEX PUT/GET server.
- Supports host baud rate from 1.2 kbps to 115.2 kbps, which is changeable by PC utility or 8 pins on chip; IrDA baud rate from 9.6 kbps to 115.2 kbps, which is flexible, setting by IrDA devices.
- Supports both IrDA Primary and Secondary mode.
- IR frame and Host buffer are 2048 bytes separately.
- Low supply voltage, 3.0 V to 3.6 V.
- Current consumption: 20 mA standby, 30 mA active.
- Small low profile plastic 52-pin QFP package.
- Available in programmed and tested chips, assembled & tested boards, or fully packaged devices.
- A ready-made IrDA-compatible evaluation dongle ACT-IR100SD is available. It is strongly recommended to evaluate ACT-IR100SD before purchasing ACT-IR8200D chip.
- A very useful Full Set Evaluation Kit is ACT-IR100SDK, which includes: ACT-IR100SD and ACT-IR4000US (notebook / desktop USB-IrDA adapter). This kit can evaluate ACT-IR100SD (connected to your device) exchanging IrDA data with ACT-IR4000US (connected to PC USB port), running under HyperTerminal with Windows IrDA driver. It can avoid debugging multiple issues: e.g. Does PDA application IrDA SW activate and behave properly with the matching protocol layer? Is this an ACT-IR100SD to host interface issue (UART data rates, flow control, data bit/parity/stop bit, UART signal pins, power levels)? Or is this a performance issue (throughput, distance, error rate/dropping bits)?

ACT-IR8200D

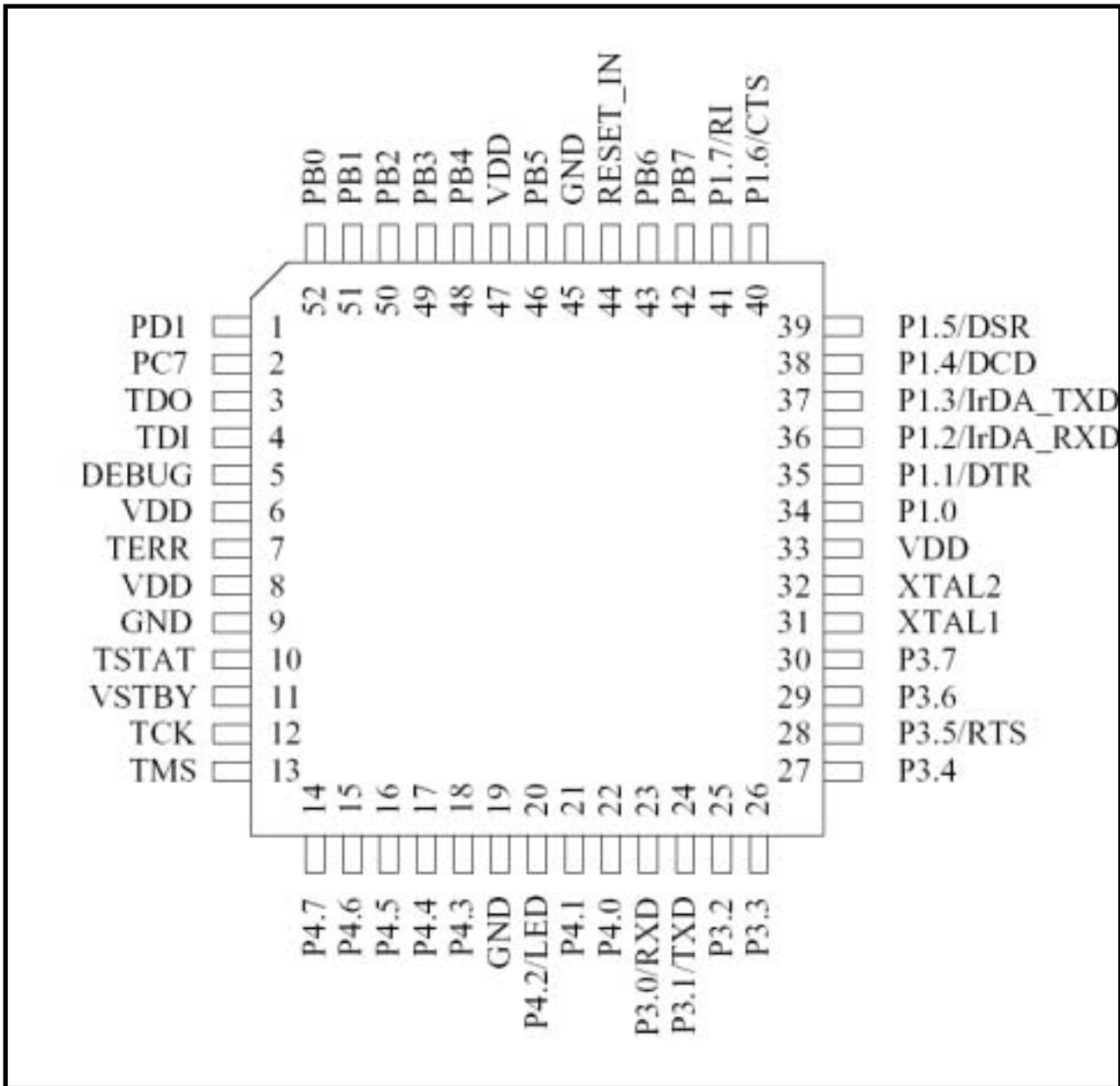

2. OVERVIEW

ACT-IR8200D is a low cost, high performance and highly integrated microcontroller, with on-chip IrDA protocol stack and on-chip infrared physical encoder/decoder. It provides a serial interface (UART) to a host device that intends to have infrared communication capability. The host device can be any equipment or device that needs to communicate with IrDA enabled devices via IrDA protocol with only a wired serial interface. ACT-IR8200D will handle all the details regarding IrDA protocols. It sends and receives user data to and from the host device via the serial interface with hardware flow control.

IrDA has two modes: Primary and Secondary. The difference between them is that Primary initiates discovery, connection sequence and negotiates IrDA protocol parameters with Secondary; while Secondary always passively waits for commands from Primary. Both modes can run different protocols respectively, and both may send or receive user data.

ACT-IR8200D supports both modes. Fig.1 is its system diagram.

Fig. 1 System Diagram

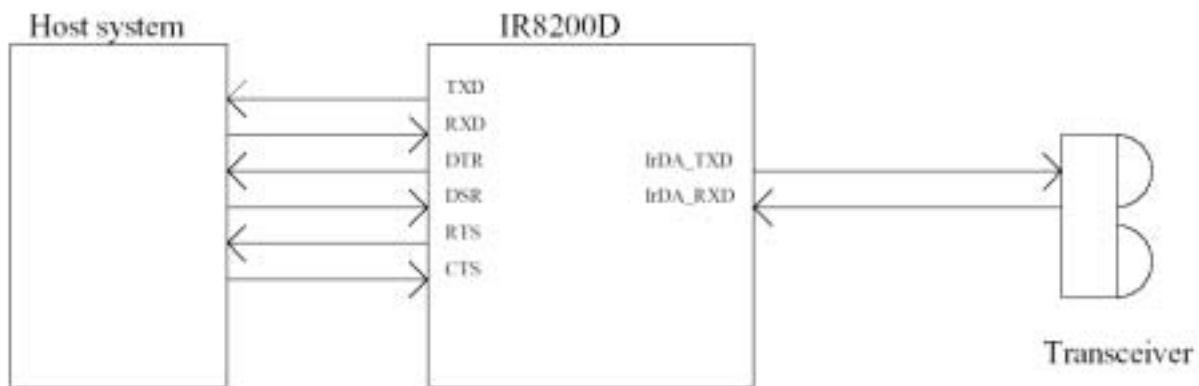

3. HOW TO CONFIGURE ACT-IR8200D?

Since ACT-IR8200D supports both Primary / Secondary modes and other parameters which provide flexibility for customer usage, the first thing you need to do is making sure what host baud rate and which protocol you require before chip is implemented on PCB. Therefore, ACTiSYS developed a Windows program named Comset_IR100SD.exe to let customer to configure ACT-IR8200D easier.

3.1. Wiring Note

Comset_IR100SD.exe program runs under Windows system (98, 98SE, Me, 2K and XP) and works with com port. So if you want to configure ACT-IR8200D on PCB, you should wire all 6 host signals of ACT-IR8200D to a DB9F connector. Those wires are TXD, RXD, DTR, DSR, RTS and CTS. After these have been done, you can change the configuration of ACT-IR8200D. Since you may sometimes need to wire those signals to other than a DB9 connector, we recommend that you can buy our ACT-IR8200D evaluation board (ACT-IR100SD) to test and configure before purchasing ACT-IR8200D. Please contact ACTiSYS to get the information of ACT-IR100SD.

Following sections show the configuration settings on three tabs of Comset_IR100SD.exe window:

3.2. The First Tab: Host Settings

It is to set the host baud rate and the hardware flow control.

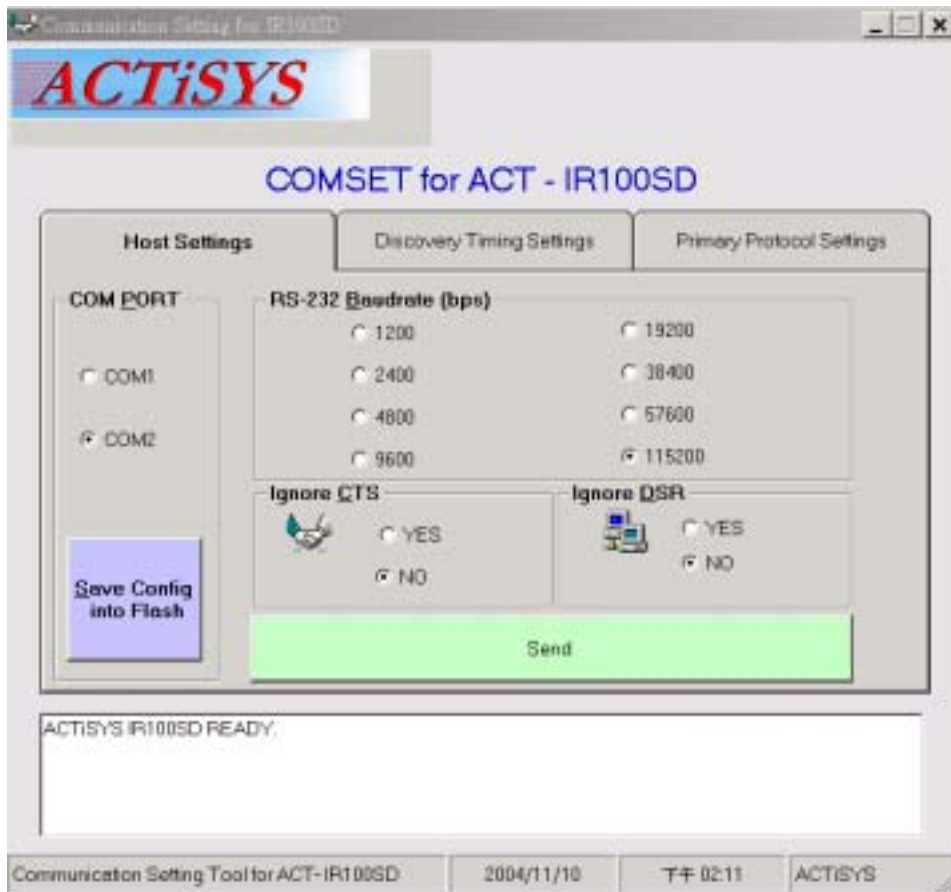

3.3. Flow Control Note

Ignore CTS: If host device has no hardware flow control signals, only Tx, Rx and GND, then you have to select “**YES**” option. ACT-IR8200D will then pass the incoming data to host and not care the status of CTS (it will ignore CTS). **Note: ACT-IR8200D is a buffer limited adapter (2K bytes for host and 2K bytes for IrDA).** If this option has been selected to “**YES**”, then it may cause data loss because of no flow control. Whereas data loss can be solved if user can send data segment by segment and every segment not exceeding 2K bytes. But normally we recommend to select “**NO**” option on this field..

Ignore DSR: If host system has no DSR signals, then this option should be set to “**YES**” to ignore DSR signal. This is what we recommend when host device is Secondary. Since DSR signal will trigger ACT-IR8200D into Primary, if you select “Primary/Secondary” on “Mode” option (on the 2nd tab) and set option “Ignore DSR” to “**YES**”, it will always be in Primary mode and no way to ask it disconnecting IrDA link once power on. In other words, once you set option “Ignore DSR” to “**YES**”, you will not be able to control ACT-IR8200D at all until power off and set it to “**NO**”. So normally we recommend to select “**NO**” on this option.

3.4. The Second Tab: Discovery Timing Settings

It is to set time interval of discovery, the slot number of discovery and the mode of ACT-IR8200D.

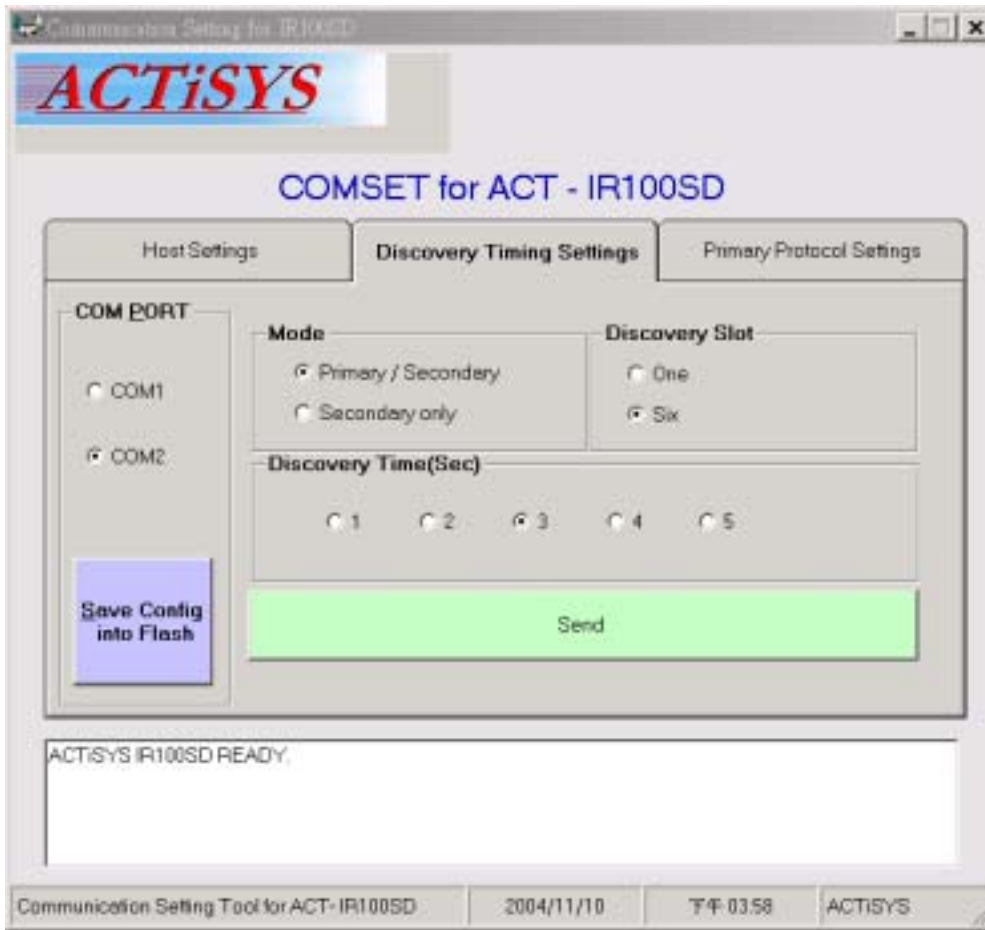

3.4.1 ACT-IR8200D supports both Primary and Secondary. It allows customer to change it.

3.4.2 Discovery time should be 3 seconds in general. If you want the discovery process faster, you can change it.

3.4.3 Discovery slot can also make discovery process faster.

3.5. The Third Tab: Primary Protocol Settings

It is to set the IrDA protocols when ACT-IR8200D is in Primary.

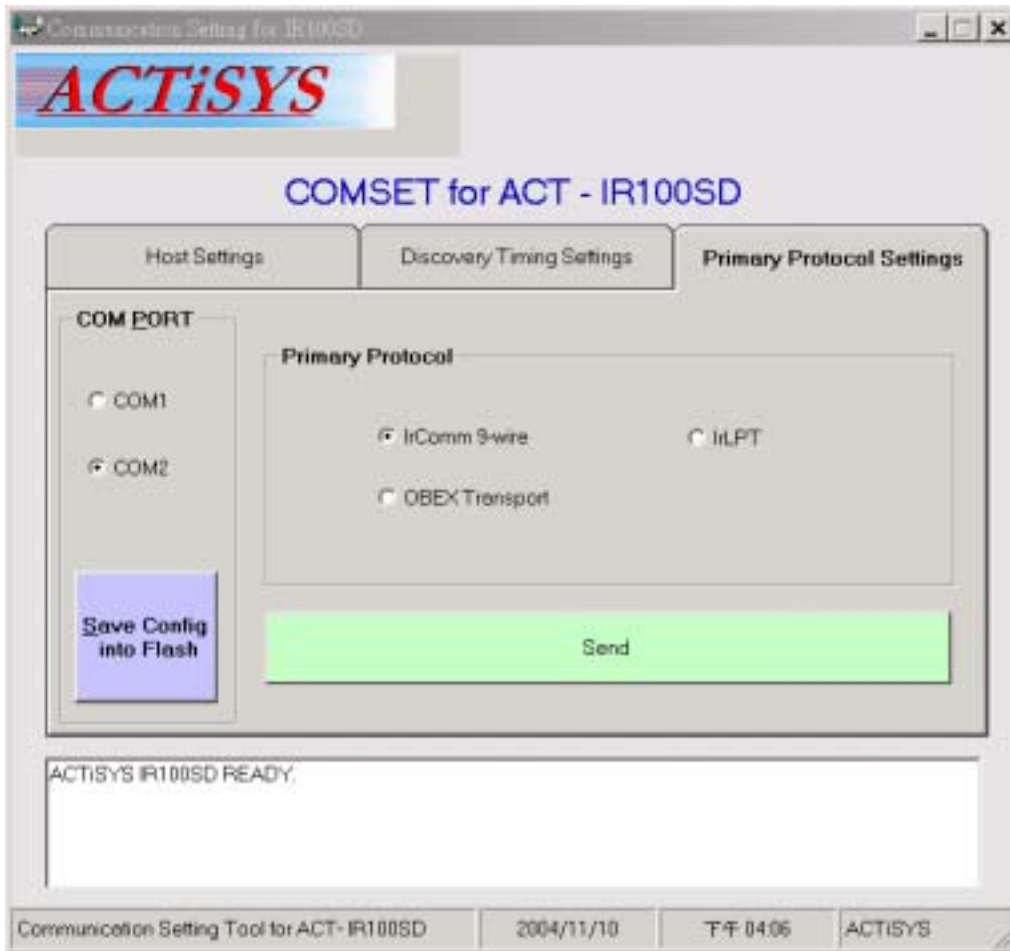

3.6. Save Configuration

After parameters being changed, you have to click “**Send**” button on those tabs you have changed first. Then click “**Save Config into Flash**” so that parameters can be configured successfully.

Instead of changing by program, there is another choice for you if you want to change the parameters manually. Or you have already soldered ACT-IR8200D on PCB. The PB7~PB0 pins on ACT-IR8200D can be configured host baud rate and hardware flow control signals to fit your requirements. Also you can change the Primary protocol or discovery time or slot here.

Please get information from tech support and refer to the pin description when required

5. PACKAGE DIMENSIONS

52-PIN QFP

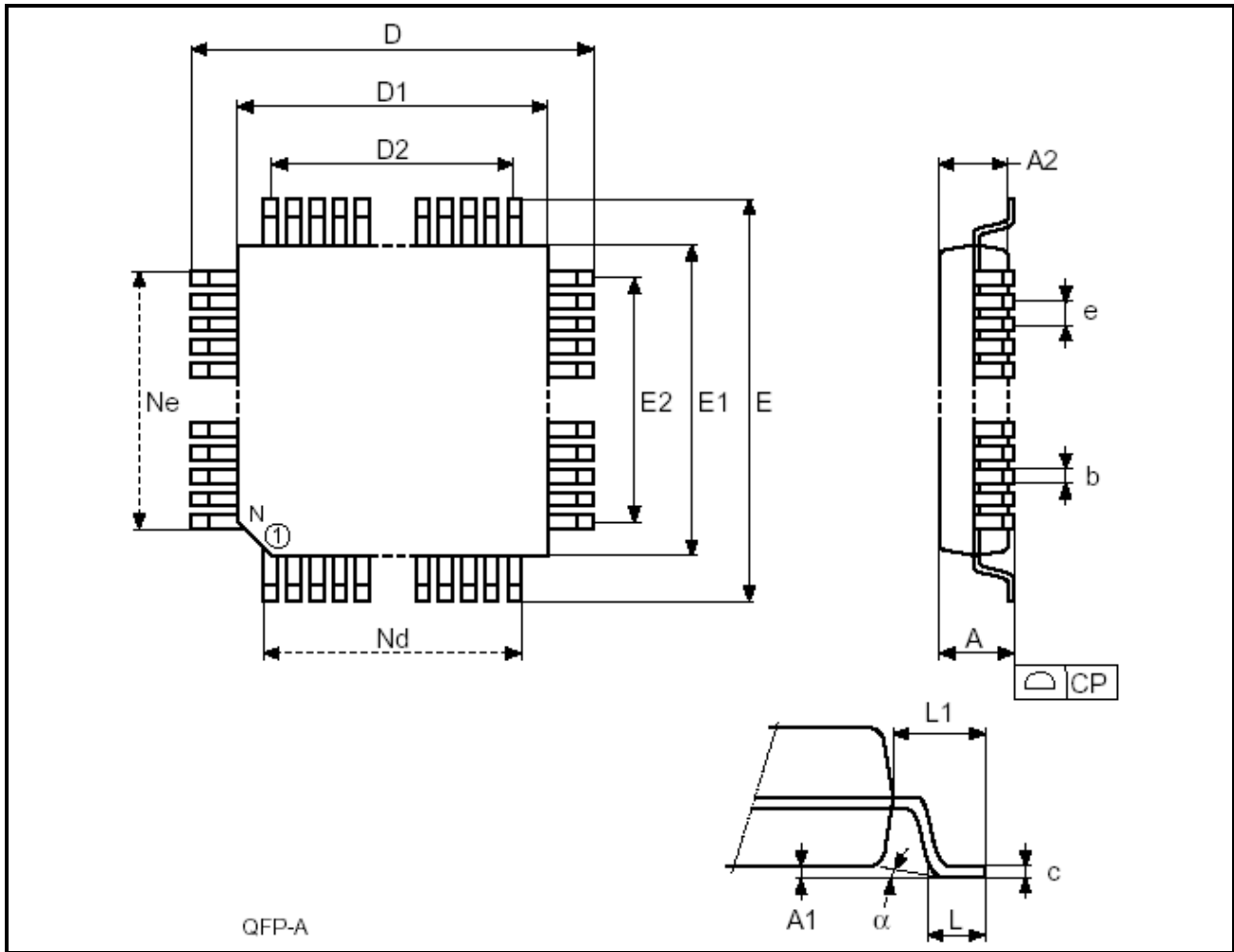

Symb	mm			inches		
	Typ	Min	Max	Typ	Min	Max
A	–	–	1.75	–	–	0.069
A1	–	0.05	0.20	–	0.002	0.008
A2	–	1.25	1.55	–	0.049	0.061
b	–	0.20	0.40	–	0.008	0.016
c	–	0.07	0.23	–	0.002	0.009
D	12.00	–	–	0.473	–	–
D1	10.00	–	–	0.394	–	–
D2						
E	12.00	–	–	0.473	–	–
E1	10.00	–	–	0.394	–	–
E2	7.80			0.307		
e	0.65	–	–	0.026	–	–
L	–	0.45	0.75	–	0.018	0.030
L1	1.00	–	–	0.039	–	–
α	–	0°	7°	–	0°	7°
n	52			52		
Nd	13			13		
Ne	13			13		
CP	–	–	0.10	–	–	0.004

6. WARRANTY INFORMATION

ACTiSYS Corporation warrants the first end-user purchaser, for a period of 1 year from the date of purchase, that this wireless interface (The Product) will be free from defective workmanship and materials, and agrees that it will, at its option, either repair the defect or replace the defective Product or part thereof at no charge to the purchaser for parts or for labor.

This warranty does not apply to any appearance items of the Product, any consumable items such as paper, ink ribbon, or batteries supplied with the Product, or to any equipment or any hardware, software, firmware, or peripheral other than the Product. This warranty does not apply to any Product the exterior of which has been damaged or defected, which has been subjected to misuse, abnormal service or handling, or which has been altered or modified in design, construction or interfacing. Tampering with Label Voids Warranty.

In order to enforce the rights under this limited warranty, the purchaser should mail, ship or carry the Product, together with proof of purchase, to ACTiSYS.

The limited warranty described above is in addition to whatever implied warranties may be granted to purchasers by law. To the extent permitted by applicable law, ALL IMPLIED WARRANTIES INCLUDE THE WARRANTIES OF MERCHANT ABILITY AND FITNESS FOR USER ARE LIMITED TO A PERIOD OF 1 YEAR FROM THE DATE OF PURCHASE. Some states do not allow limitations on how long an implied warranty lasts, so the above limitation may not apply to you.

Neither the sales personnel of the seller nor any other person is authorized to make any warranties other than those described above, or to extend the duration of any warranties beyond the time period described above on behalf of ACTiSYS Corporation.

The warranties described above shall be the sole and exclusive remedy available to the purchaser. Correction of defects, in the manner and for the period of time described above, shall constitute full satisfaction of all claims, whether based on contract, negligence, strict liability or otherwise. In no event shall ACTiSYS Corporation be liable or in any way responsible, for any damages or defects in the Product which were caused by repair or attempted repairs performed by anyone other than ACTiSYS technician. Nor shall ACTiSYS Corporation be liable or in any way responsible for any incidental or consequential economic or property damage. Some states do not allow the exclusion of incidental or consequential damages, so the above exclusion may not apply to you.

FOR YOUR RECORDS

For your assistance in reporting this product in case of loss or theft, please record below the model number and serial, which are located on the bottom of the case. Please retain this information.

Model Number:

Serial Number:

Date of Purchase:



7. CONTACT INFORMATION

GO WIRELESS WITH ACTiSYS IR



ACTiSYS
The Wireless Infra-red Expert

- ◆ IrDA Protocol Software For Portable Devices
- ◆ IrDA Test Software For Hardware Systems
- ◆ IrDA Printer And Computer Adapters

115.2K, 4M and 16M bps



IR100M/1000M

IR2000L

IR220L/L+

ACTiSYS Corporation
48511 Warm Springs Blvd, Suite 206
Fremont, CA 94539, USA
TEL:+1-510-490-8024, FAX:+1-510-623-7268
E-Mail: irda-info@actisys.com
Web: <http://www.actisys.com>