



48511 Warm Springs Blvd., Suite 206, Fremont CA 94539  
Tel: (510) 490-8024 Fax: (510) 623-7268  
Website: <http://www.actisys.com> E-mail: [irda-info@actisys.com](mailto:irda-info@actisys.com)

# **ACT-IR220VACF**

## ***IRDA SIR Encoder/Decoder IC Specification***

© Copyright 2002-2005 ACTiSYS Corporation,  
*All Rights Reserved*

Jun. 22, 2005 Rev.1.1.2

*ACTiSYS reserves the right to make changes without further notice to any products herein to improve reliability, function or design. ACTiSYS does not assume any liability arising out of the application or use of any product or circuit described herein.*

<b>Revision History</b>		
<b>Revision</b>	<b>Date</b>	<b>Comment</b>
Rev. 1.0	06/28/2001	Draft Preliminary Design Specification for internal review.
Rev. 1.1	09/13/2002	Add Electrical Characteristics
Rev. 1.1.1	11/12/2002	Editorial Corrections
Rev. 1.1.2	06/22/2005	Correct the operating voltage.

Description.....	4
Features .....	4
Block Diagram .....	4
Pin Assignment and Description .....	5
Control Function .....	6
Application Circuit.....	7
Electrical Characteristics .....	8
Package Dimensions.....	10
Warranty Information .....	11
Contact Information .....	12

## Description

The ACT-IR220VACF is a half-duplex infrared communication processor that encodes RS232 compatible electrical signal pulses to IrDA compatible electrical pulses, and decodes IrDA compatible electrical pulses to RS232 (needs level converter) pulses, ACT-IR220VACF supports data baud rate from 9.6Kbps to 115.2Kbps.

The ACT-IR220VACF uses crystal clock 3.6864 MHz for its pulse stretching and shortening. The IrPHY specification allows two kinds of modulations: 3/16 of a bit duration pulse, or minimum pulse duration of 1.63  $\mu$ s, we are using minimum pulse duration of 1.63  $\mu$ s to modulate bit data.

## Features

- IrPHY encoding/decoding and interfaces directly to IrDA transceivers.
- 2.7 V to 5.5 V operating voltage.
- Using minimum pulse duration of 1.63  $\mu$ s to modulate bit data.
- Programmable baud clock generator (9600bps to 115.2 Kbps) 5 baud rates.
- Low operating current
- SOP14 – package

## Block Diagram

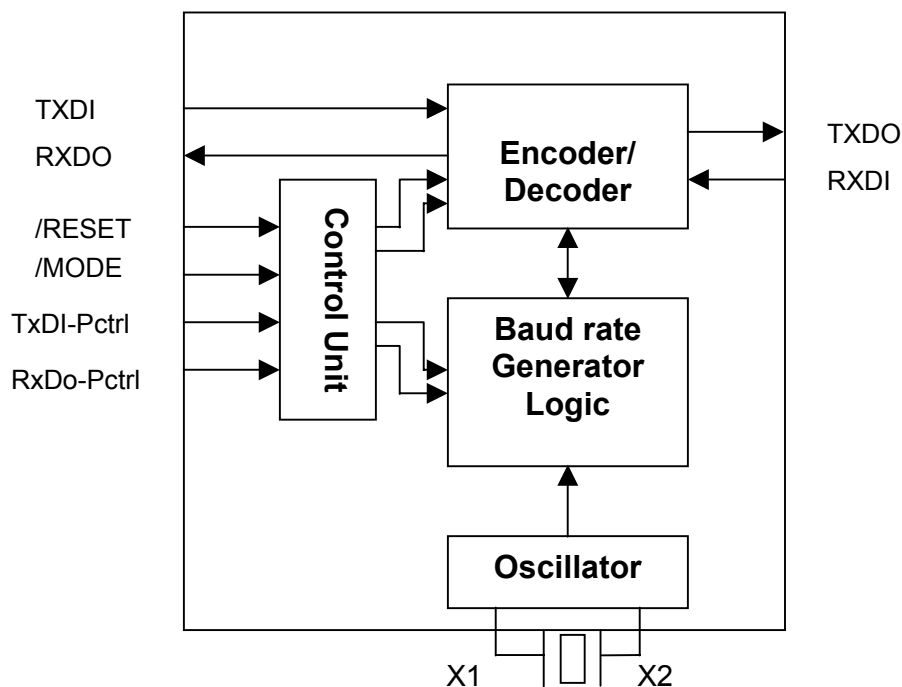







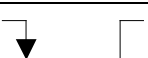
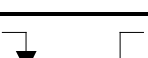
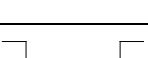
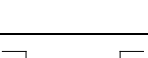
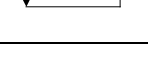
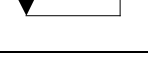

Figure 1. Block diagram

## Pin Assignment and Description

Symbol	Pin No.	I/O Type	Descriptions
NC	1 & 8		No connect.
RXDO	2	Output	Receiving Data Output. It is active when infrared signals come from RXDI pin. It depends on RXDO-PCTRL pin to control active level. It can be connected to the UART interface of micro controller.
 RESET	3	Input	Reset chip signal. Low active. Pulling this pin Low for 200ns, it will reset the baud rate to 9.6kbps.
 MODE	4	Input	Changing mode signal. Low active. Pulling this pin Low for 200ns, it will change the chip baud rate to next speed. There are 5 baud rates supported by IR220VACF.
TXDI	5	Input	Transmitting Data Input. The data that comes from TXDI pin will be translated to infrared signals and sent to TXDO pin. It depends on TXDI-PCTRL pin to control active level. It can be connected to UART interface of micro controller.
TXDI-PCTRL	6	Input	When TXDI-PCTRL is "LOW", the TXDI will be HIGH active. When TXDI-PCTRL is "HIGH", TXDI will be change to LOW active.
GND	7	Power	Ground.
XTAL	9 & 10		Crystal input clock, 3.6864 MHz nominal. Input for external clock.
RXDI	11	Input	Infrared signals input. This pin is connected to the Infrared signals that comes from receiving pin of transceiver module
RXDO-PCTRL	12	Input	When RXDO-PCTRL is "LOW", the RXDO will be HIGH active, when RXDO-PCTRL is "HIGH", RXDO will be change to LOW active.
TXDO	13	Output	Infrared signals output. This pin is connected and sends infrared signals to transmitting pin of transceiver module.
VCC	14		Power supply.

## Control Function

The following table shows how IR220VACF changes its baud rate. When IR220VACF is powered, It stays at 9.6Kbps. By pulling the /MODE signal low for more then 200ns, you can change baud rate. Pulls one low pulse, change to next baud rate. Another low pulse, change to another baud rate. There are totally 5 baud rates can be selected.

Symbol	RESET	MODE	Descriptions
9.6Kbps		Don't Care	Basic backward Compatible modes
19.2Kbps	Hi	1 x 	
57.6Kbps	Hi	2 x 	
115.2Kbps	Hi	3 x 	
38.4Kbps	Hi	4 x 	
No use	Hi	5 x 	New feature
No use	Hi	6 x 	
No use	Hi	7 x 	
No use	Hi	8 x 	
ASK mode	Hi	8 x 	

**Application Circuit**

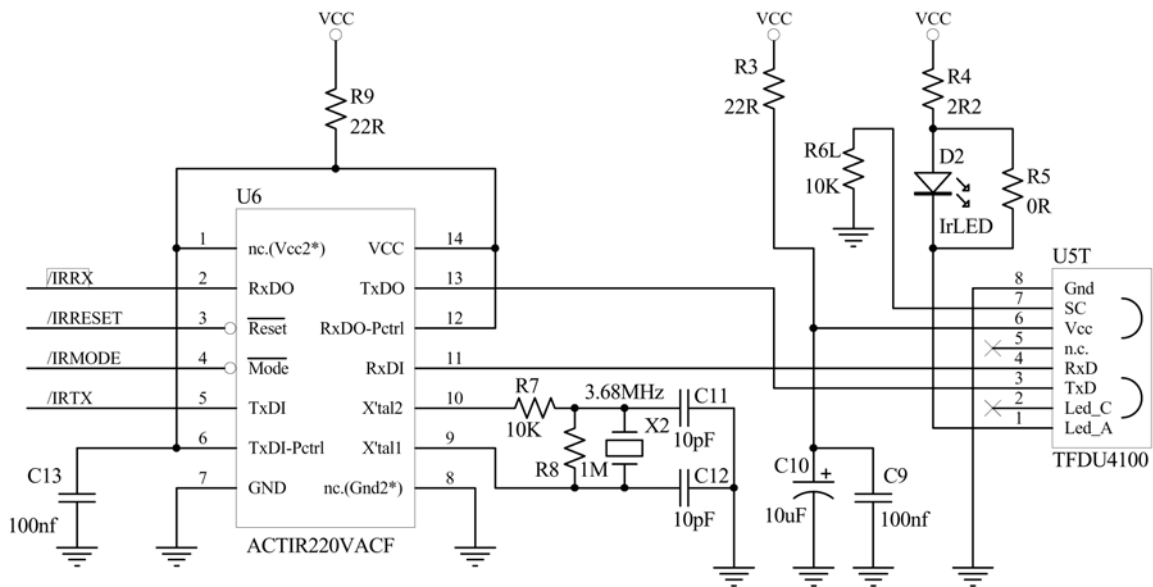

Figure 2. ACT-IR220VACF application circuit

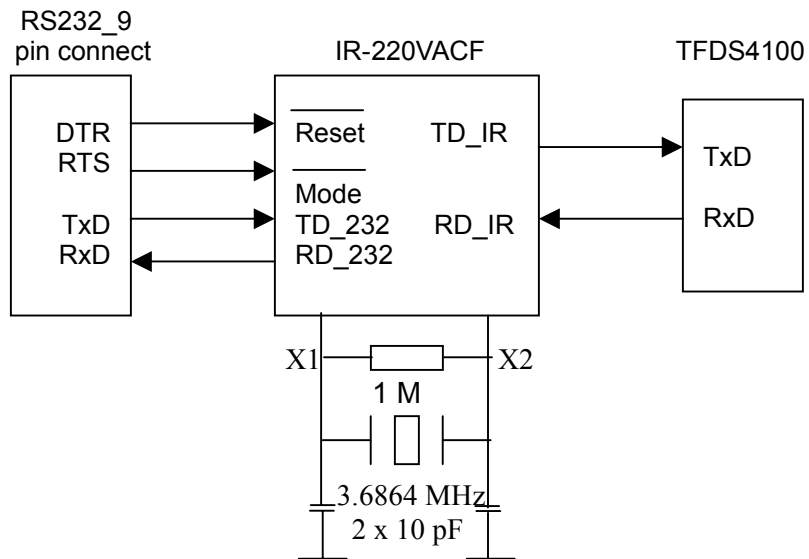

Figure 3. Application Block Diagram

Table 1. Recommended Application Circuit Components

Component	Recommended Value	Component	Recommended Value
C9	100 nF	R5	0 R
C10	10 $\mu$ F	R6	10K R
C11	10 pF	R7	10K R
C12	10 pF	R8	1M R
C13	100 nF	R9	22 R
R3	22 R	D2	Ir LED
R4	2R2	X2	3.686400 MHz Crystal

## Electrical Characteristics

### Absolute Maximum Ratings

Symbol	Parameter	Rating	Units
V <sub>CC</sub>	Power Supply	-0.3 to 6.0	V
V <sub>IN</sub>	Input Voltage	-0.3 to V <sub>CC</sub> +0.3	V
V <sub>OUT</sub>	Output Voltage	-0.3 to V <sub>CC</sub> +0.3	V
T <sub>STG</sub>	Storage Temperature	-40 to 125	°C

### Recommended Operation Conditions

Symbol	Parameter	Min	TYP	Max	Units
V <sub>CC</sub>	Power Supply	2.7	5.0	5.25	V
V <sub>IN</sub>	Input Voltage	0		V <sub>CC</sub>	V
T <sub>OPR</sub>	Storage Temperature	0		70	°C

### General DC Characteristics

Symbol	Parameter	Conditions	Min	TYP	Max	Units
I <sub>IL</sub>	Input low current	No pull-up or pull-down	-1		1	$\mu$ A
I <sub>IH</sub>	Input high current	No pull-up or pull-down	-1		1	$\mu$ A
I <sub>OZ</sub>	Tri-state leakage current		-10		10	$\mu$ A
C <sub>IN</sub>	Input capacitance			3		pF
C <sub>OUT</sub>	Output capacitance			3 to 6		pF
C <sub>BID</sub>	Bi-directional buffer capacitance			3 to 6		pF

**DC Electrical Characteristics for 5 volts operation**

 (Under Recommended Operation Conditions and  $V_{cc}=4.75v \sim 5.25v$ ,  $T_j=0^{\circ}C$  to  $+70^{\circ}C$ )

Symbol	Parameter	Conditions	Min	TYP	Max	Units
VIL	Input Low Voltage	TTL			0.8	V
VIL	Input Low Voltage	CMOS			$0.3 \cdot V_{cc}$	V
VIL	Schmitt input Low Voltage	TTL		1.12		V
VIL	Schmitt input Low Voltage	CMOS		1.76		V
VIH	Input High Voltage	TTL	2.2			V
VIH	Input High Voltage	CMOS	$0.7 \cdot V_{cc}$			V
VIH	Schmitt input High Voltage	TTL		2.00		V
VIH	Schmitt input High Voltage	CMOS		3.20		V
VOL	Output low voltage	$I_{OL}=4,8,12,16,24$ mA			0.4	V
VOH	Output high voltage	$V_{OH}=4,8,12,16,24$ mA	3.5			V
PG	Gate Power	Per Gate/MHz		4.7		$\mu W$
RI	Input Pull-up/down resistance	$V_{il}=0v$ or $V_{ih}=V_{cc}$		50		$K\Omega$

**Package Dimensions**

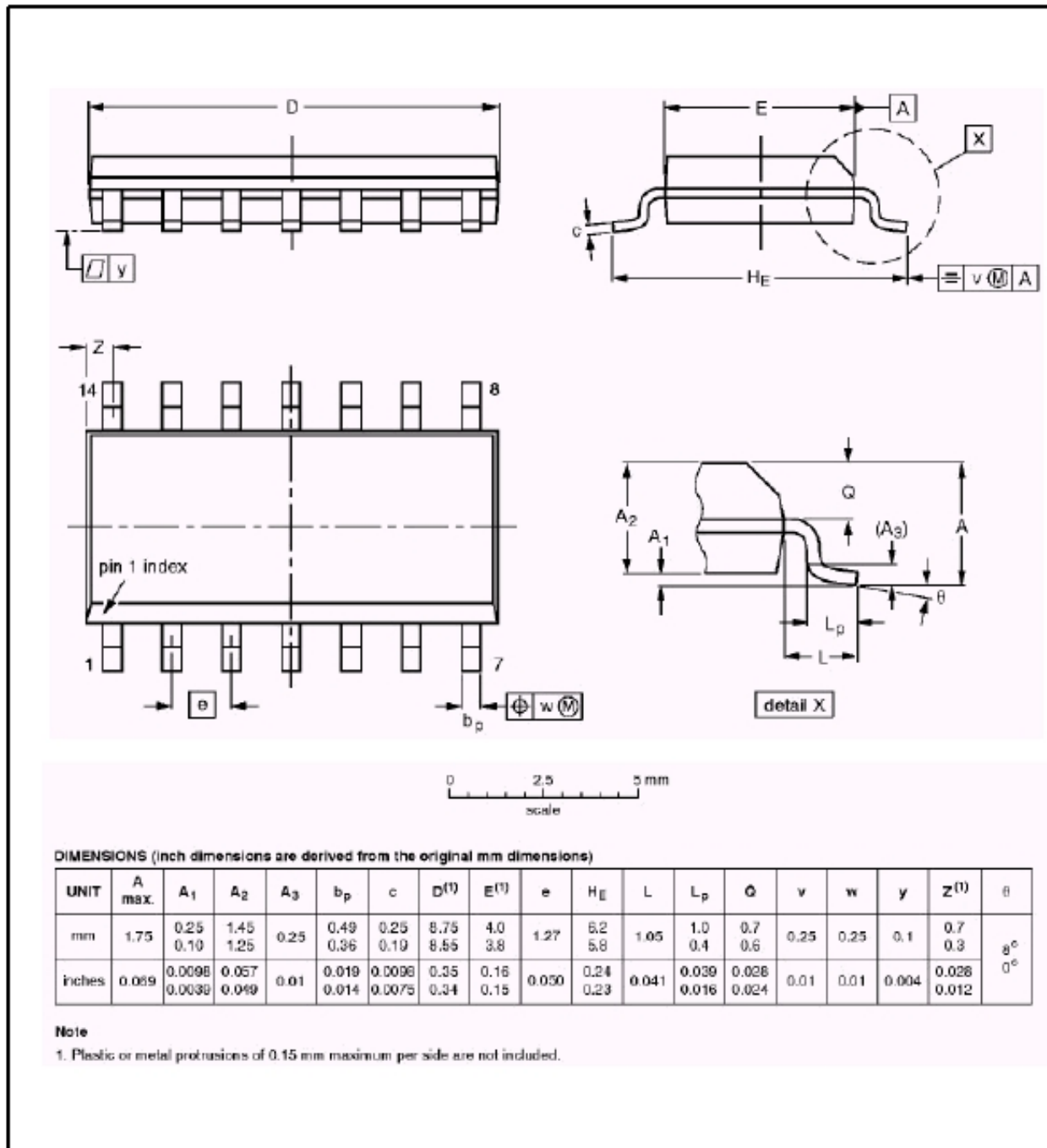

## Warranty Information

ACTiSYS Corporation warrants to the first consumer purchaser, for a period of 1 year from the date of purchase, that this wireless interface (The Product?) Will be free from defective workmanship and materials, and agrees that it will, at its option, either repair the defect or replace the defective Product or part thereof at no charge to the purchaser for parts or for labor.

This warranty does not apply to any appearance items of the Product, any consumable items such as paper, ink ribbon, or batteries supplied with the Product, or to any equipment or any hardware, software, firmware, or peripheral other than the Product. This warranty does not apply to any Product the exterior of which has been damaged or defected, which has been subjected to misuse, abnormal service or handling, or which has been altered or modified in design, construction or interfacing. Tampering With Label Voids Warranty.

In order to enforce the rights under this limited warranty, the purchaser should mail, ship, or carry the Product, together with proof of purchase, to ACTiSYS .

The limited warranty described above is in addition to whatever implied warranties may be granted to purchasers by law. To the extent permitted by applicable law, **ALL IMPLIED WARRANTIES INCLUDING THE WARRANTIES OF MERCHANT ABILITY AND FITNESS FOR USE ARE LIMITED TO A PERIOD OF 1 YEAR FROM THE DATE OF PURCHASE.** Some states do not allow limitations on how long an implied warranty lasts, so the above limitation may not apply to you.

Neither the sales personnel of the seller nor any other person is authorized to make any warranties other than those described above, or to extend the duration of any warranties beyond the time period described above on behalf of ACTiSYS Corporation.

The warranties described above shall be the sole and exclusive remedy available to the purchaser. Correction of defects, in the manner and for the period of time described above, shall constitute full satisfaction of all claims, whether based on contract, negligence, strict liability or otherwise. In no event shall ACTiSYS Corporation be liable or in any way responsible, for any damages or defects in the Product which were caused by repairs or attempted repairs performed by anyone other than ACTiSYS technician. Nor shall ACTiSYS Corporation be liable or in any way responsible for any incidental or consequential economic or property damage. Some states do not allow the exclusion of incidental or consequential damages, so the above exclusion may not apply to you.

**Contact Information**

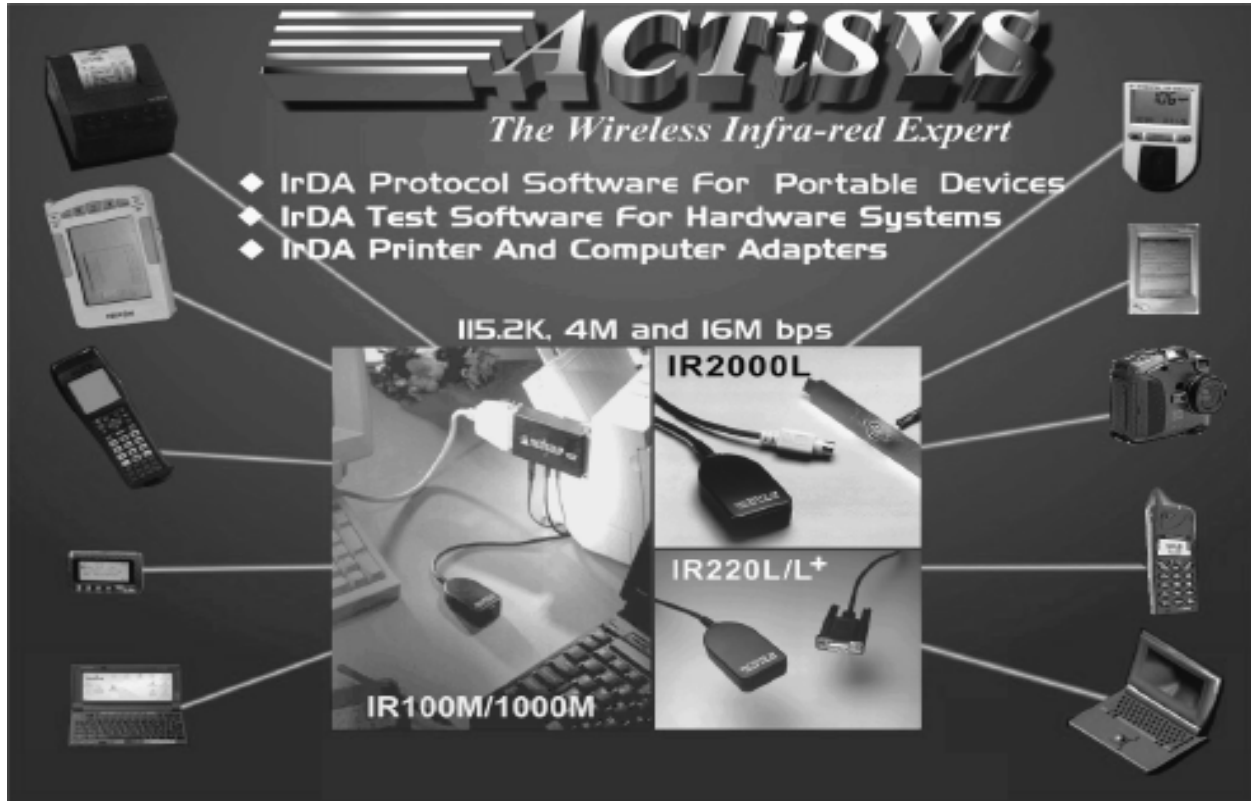

ACTiSYS Corporation.  
48511 Warm Springs Blvd, Suite 206  
Fremont, CA 94539, USA  
TEL: (510) 490-8024, FAX: (510) 623-7268  
E-Mail: [irda-support@actisys.com](mailto:irda-support@actisys.com)  
Web: [www.actisys.com](http://www.actisys.com)